

UH400A/UH400™

TECHNICAL DATA

Digital Hybrid Wireless™ Plug-On Transmitter

- Converts microphones with XLR jacks to wireless operation
- Selectable 5, 18 and 48 volt phantom power plus off position for dynamic microphones
- 256 synthesized UHF frequencies
- 100 mW output power
- Rugged machined aluminum housing



The UH400A Digital Hybrid™ synthesized UHF plug-on transmitter has a DSP-based design that allows the transmitter to operate in its native Digital Hybrid Wireless™ mode, Lectrosonics 200 Series, 100 Series, IFB product groups, plus two modes for compatibility with analog receivers from other manufacturers. A unique multi-voltage phantom power feature allows the transmitter to be used with most any microphone, including high-current condenser types, expanding its usefulness in high-end applications such as motion picture production.

The transmitter provides 256 frequencies in standard frequency blocks, selected with two rotary switches on the side of the housing. The input amplifier uses an ultra low noise op-amp for quiet operation. It is gain controlled with a wide range dual envelope limiter, providing over 30 dB of headroom above full modulation. A 24-bit A-D converter digitizes the audio, then filters supersonic noise above 21 kHz. The resulting signal is encoded with a proprietary algorithm to produce an analog data signal for RF transmission. The underlying RF link is an optimized FM system with +/-75 kHz wide deviation for a high signal to noise ratio.

The antenna is formed between the lower housing of the transmitter and the attached system. It functions as a dipole radiator when attached to a hand-held microphone and somewhat like a ground plane antenna when connected into a mixer.

Digital Hybrid Wireless™ is a revolutionary new design that combines digital audio with an analog FM radio link to provide outstanding audio quality and the exemplary RF performance of the finest analog wireless systems.

The design overcomes channel noise in a dramatically new way, digitally encoding the audio in the transmitter and decoding it in the receiver, yet still sending the encoded information via an analog FM wireless link. This proprietary algorithm is not a digital implementation of an analog compandor. Instead, it is a technique which can be accomplished only in the digital domain.

The process eliminates compandor artifacts, expanding the applications to include test and measurement of acoustic spaces.

*US Patent 7,225,135

Phantom power is selectable at 5V, 15V and 48V for electret condenser microphones, or it can be turned off for use with dynamic microphones and modest line level inputs. The selector switch is located on a recessed control panel, with a flush switch handle to prevent inadvertent settings.

The UH400A is powered by a single 9 volt battery and provides a full 100 mW output over the life of the battery.

DSP-Based Pilot Tone & Compatibility

The DSP eliminates the need for fragile crystals, plus it allows a different pilot tone for each of the 256 frequencies in the tuning range of a system's frequency block. Individual pilot tones virtually eliminate squelch problems in multichannel systems where a pilot tone signal can appear in the wrong receiver via intermodulation products. A circulator/isolator in the output stage further ensures against intermodulation interference.

Outstanding Audio Performance

The audio performance of the overall hybrid system is depicted in the graph below. Distortion in the overall system is extremely low over the entire usable audio band.

The frequency response is extremely flat over a wide range up to 20 kHz. The low frequency response is then rolled off at 70 Hz*, and the input includes a wide range limiter with 30 dB of headroom.

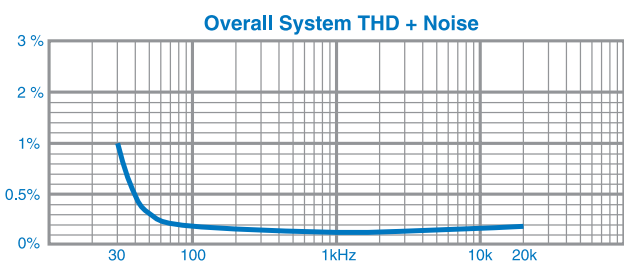

* To reduce low frequency noise



Controls and Indicators

The input jack is a standard XLR female that accepts all types of dynamic and condenser microphones. The input level is indicated by dual-color LEDs next to the connector. As the input level increases, the LEDs progress from green to red to indicate the level and the onset of limiting. Battery status is indicated by a dual-color LED, also on

the top panel. As the battery voltage drops, the LED will change from green to red, and then start blinking as a warning when the battery is near the end of its life.

The input coupler, housing and panels are constructed of machined aluminum with anodized and powder coated finishes for ruggedness needed in the field.

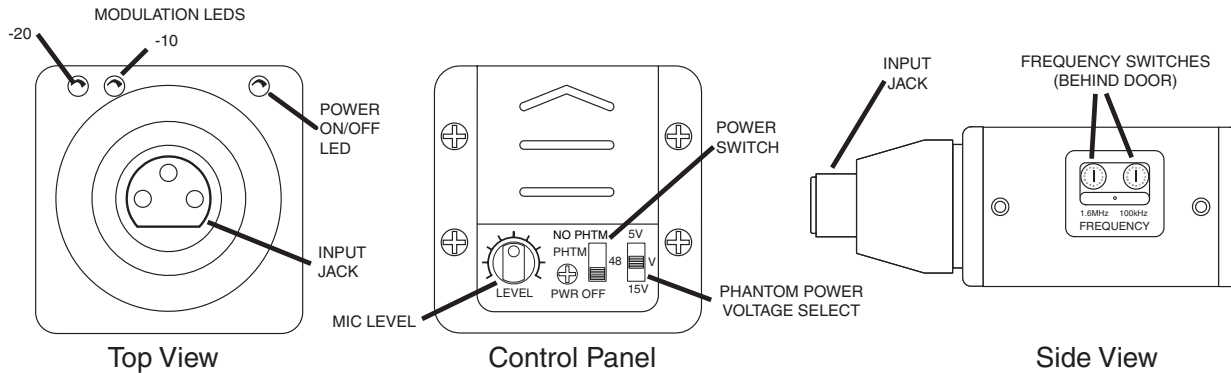

Specifications and Features

Frequency selection: 256 frequencies in 100 kHz steps

Operating Frequencies (MHz):

Block 470	470.100 - 495.600
Block 19	486.400 - 511.900
Block 20	512.000 - 537.500
Block 21	537.600 - 563.100
Block 22	563.200 - 588.700
Block 23	588.800 - 607.900; 614.100 - 614.300
Block 24	614.400 - 639.900
Block 25	640.000 - 665.500
Block 26	665.600 - 691.100
Block 27	691.200 - 716.700
Block 28	716.800 - 742.300
Block 29	742.400 - 767.900

RF Power output: 100 mW (nominal)

Pilot tone: 25 to 32 kHz; 5 kHz deviation
(in the 400 Series operating mode)

Frequency stability: ± 0.002%

Deviation: ± 75 kHz (max)

Spurious radiation: 60 dB below carrier

Equivalent input noise: -118 dBV (A-weighted)

Input level: Nominal 2 mV to 300 mV, before limiting.
Greater than 1V maximum, with limiting.

Input impedance: 1k Ohm

Input limiter: Dual envelope "soft" limiter; greater than 30 dB range

Gain control range: 43 dB; semi-log rotary control

Modulation indicators: Dual bi-color LEDs indicate modulation of
-20, -10, 0, +10 dB referenced to full modulation

Audio Performance (overall system):

Frequency Response:	UH400a: 90 Hz to 20 kHz (+/-1dB); low frequency roll-off is -3 dB at 70 Hz
	UH400TM: 40 Hz to 20 kHz (+/-1dB); low frequency roll-off is -3 dB at 35 Hz

THD: 0.2% (typ. 100 Hz to 20 kHz - see graph)

SNR at receiver output:

Note: The dual envelope "soft" limiter provides exceptionally good handling of transients using variable attack and release time constants. Once activated, the limiter compresses 30+ dB of transmitter input range into 4.5 dB of receiver output range, thus reducing the measured figure for SNR without limiting by 4.5 dB.

SmartNR	no limiting	w/limiting
OFF	103.5	108.0
NORMAL	107.0	111.5
FULL	108.5	113.0

Input Dynamic Range: 125 dB (with full Tx limiting)

Controls:

- Power/Phantom "ON-OFF" switch
- Phantom voltage selector switch
- Audio input gain knob
- Two 16-position rotary switches adjust transmitter frequency

Audio Input Jack: Standard 3-pin XLR (female)

Phantom Power Selector: 5V @ 18 mA max., 15V @ 15 mA max. and 48 V @ 15 mA max., plus "OFF"

Antenna: Housing and attached microphone form the antenna

Battery: Precision compartment auto-adjusts to accept any known alkaline 9 Volt battery.

Battery Life: 4.5 hours (alkaline); 12 hours (lithium)
(battery life varies with the phantom power selection)

Weight: 6.6 ozs. - 187 grams
(including lithium 9V battery & antenna)

Dimensions: 4.18 x 1.65 x 1.58 inches

Emission Designator: 190KF3E

