

# SM Series

## TECHNICAL DATA

### Digital Hybrid Wireless™ Super-Miniature UHF Transmitters SM, SMD, SMQ, RM

- Miniature splash-proof housing and panel
- Membrane switches and LCD interface
- Servo bias input preamp for any microphone
- Superhard corrosion-resistant finish

- 100 mW and 250 mW models
- Digital Hybrid and analog compatibility
- Audio tone remote-controlled setup

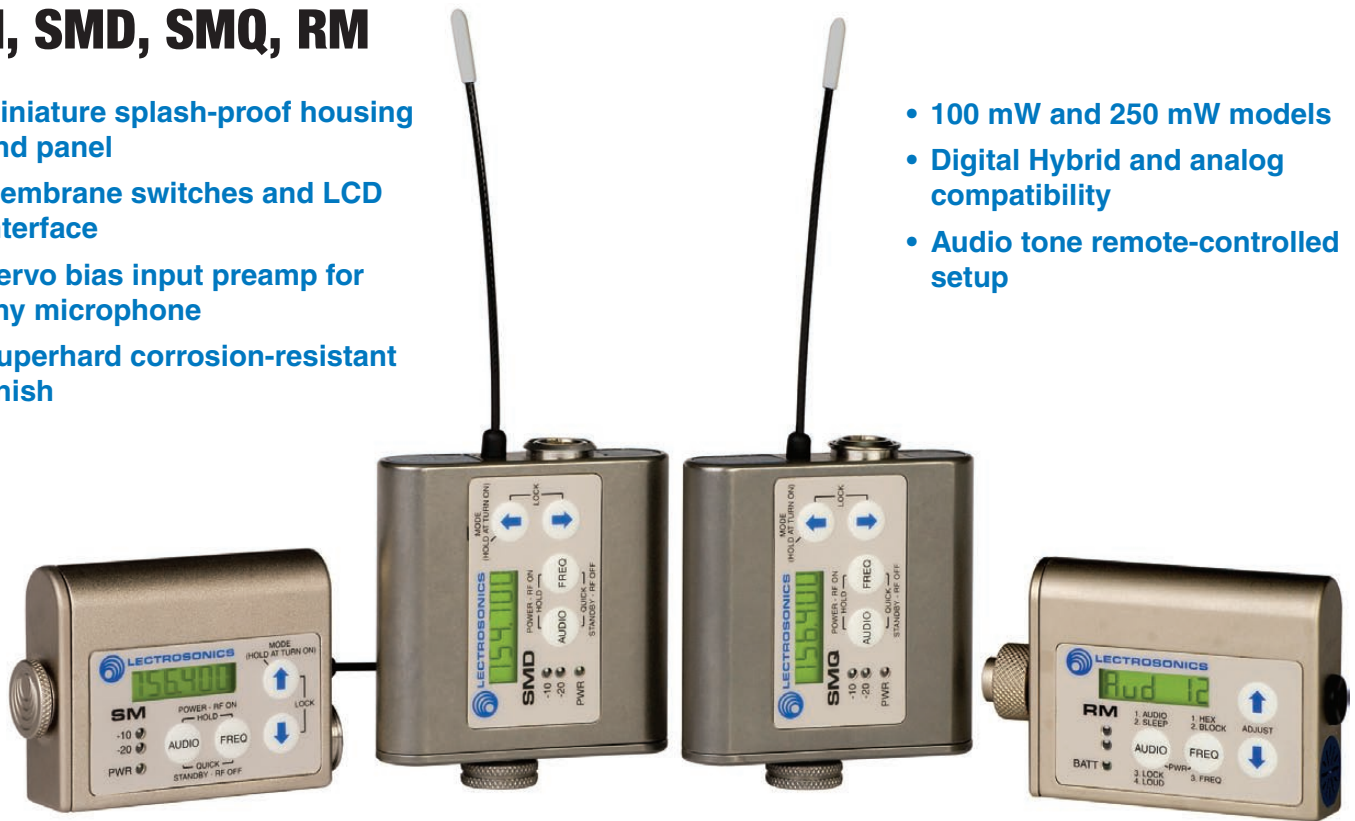

The SM Series family brings Digital Hybrid Wireless™ technology to miniature transmitters in several different configurations for essentially any wireless microphone application with a lavalier microphone. The tiny size of the single battery SM model makes concealment easy, yet with a full 100 mW output, it does not sacrifice performance. The dual battery SMD model doubles the battery life of the SM with the same feature set. The SMQ offers 250 mW RF output power to extend operating range and the unique RM provides hands-free remote control for all three models. Switching power supplies throughout the design allow long battery life with NiMH batteries.

Setup and control is simplified with membrane switches and an LCD interface. Multiple functions are clearly

marked on the panel, with on-screen prompts on the LCD as reminders when another switch must be held or the selection is locked out.

The innovative servo bias input on the standard 5-pin connector provides a programmable, regulated voltage to accommodate a wide variety of electret microphones. It is no longer necessary to install resistive pads for some mics to prevent overload of the input stage, divide the bias voltage down for some low voltage mics, or reduce the limiter range at minimum gain settings. To simplify wiring connectors, a single configuration for all microphones is now available for SM Series transmitter inputs, and an alternate wiring configuration works well with SM Series and all other 5-pin inputs on Lectrosonics transmitters. Two bicolor LEDs make adjusting input levels for proper modulation easy and accurate.

The splash-proof SM housing is machined out of a single block of aluminum, which is then plated with a superhard, non-corrosive coating. The unit is equally at home in theatre, television and film where temperature and environmental extremes require superior performance under the most demanding conditions.

**Digital Hybrid Wireless™\*** is a revolutionary new design that combines digital audio with an analog FM radio link to provide outstanding audio quality and the exemplary RF performance of the finest analog wireless systems.

This overcomes channel noise in a dramatically new way, digitally encoding the audio in the transmitter and decoding it in the receiver, yet still sending the encoded information via an analog FM wireless link. This proprietary algorithm is not a digital implementation of an analog compandor. Instead, it is a technique which can be accomplished only in the digital domain.

The process eliminates compandor artifacts, expanding the applications to include test and measurement of acoustic spaces and musical instruments.

\*US Patent Pending

## 100 mW 250 mW

Despite its tiny size, the standard SM model provides a full 100 mW output power with over 5 hours of operation on a single NiMH rechargeable AA battery. The addition of a second battery on the SMQ model provides the additional power needed to allow 250 mW of RF output and over 7 hours of operating time.

## DSP-Based Pilot Tone & Compatibility

The DSP eliminates the need for fragile crystals, plus it allows for a different pilot tone frequency for each of the 256 frequencies in the tuning range of the wireless system. Individual pilot tones significantly reduce squelch problems in multichannel systems where a pilot tone signal can appear in the wrong receiver via intermodulation products.

The DSP also offers compatibility modes to allow backward compatibility with all Lectrosonics IFB systems, 100/200 Series systems and analog receivers from some other manufacturers in addition to its native Digital Hybrid operating mode.

## Input Limiter

A DSP-controlled analog audio limiter is employed before the analog-to-digital converter. The limiter has a range of more than 30 dB for excellent overload protection. A dual release envelope makes the limiter acoustically transparent while maintaining low distortion. The limiter recovers quickly from brief transients, so that its action is hidden from the listener, but recovers slowly from sustained high levels, to keep audio distortion low and preserve short term dynamic changes.

The bicolor LEDs indicate limiter activity accurately to assist in setting the input gain for optimal signal to noise ratio and dynamic range.

## Circulator/Isolator

The transmitter RF output circuit includes a specialized RF device called a “circulator/isolator” or simply “isolator” using a magnetically polarized ferrite to allow RF signals to pass through to the antenna, but block them from coming backward into the transmitter output section. This greatly reduces RF intermodulation produced in the transmitter output stages when multiple units are used in close proximity (a few feet apart). The isolator also helps protect the output stage from electrostatic shock delivered to the antenna. Isolators are common in broadcast and commercial applications, but because of their high cost it is unusual to find them in wireless microphone systems.

## SM Series Transmitter Block Diagram

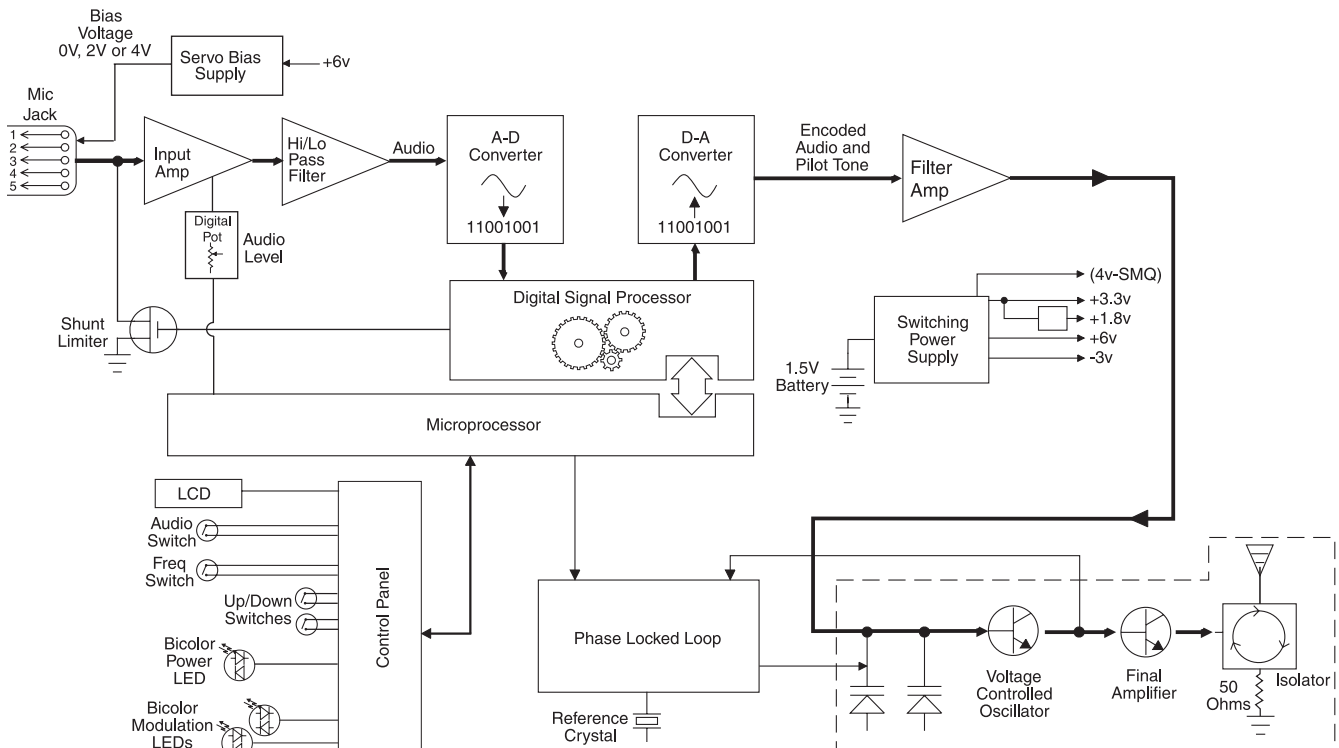

# RM Remote Control for SM Series Transmitters

The RM gives you remote control of SM Series Transmitters using an audible tone delivered to the microphone in the wireless system. Operating parameters on the wireless transmitter can be set by holding the speaker on the RM close to the microphone and pressing the pushbutton. A “dweedle” tone will play from the RM speaker into the microphone and the parameter on the transmitter will be set immediately. Adjustments can be made to set:

- Audio input gain
- Frequency
- Lock or Unlock Modes
- Sleep Mode ON/OFF

The flexible, intuitive interface on the RM makes setting these parameters quick and easy. The “dweedle” tones used to signal the transmitter are complex and can be detected in the midst of noise, yet they cannot be mistaken for the natural sound entering the microphone.



A single RM is capable of controlling any SM Series transmitter in any frequency block. Since it can simultaneously control multiple transmitters, the loudness of the tone is adjustable to suit different situations. With the volume turned up, changes can be made at a distance of up to 6 feet from the microphone. The volume can also be turned down so that only microphones within a few inches of the speaker will pick up the tone.

The RM eliminates the need to disturb wardrobe or talent other than to make a quick, hands-free pause to send the dweedle tone into the microphone. Since the microphone is always positioned to pick up sound from the talker’s voice, it is always accessible for setup changes using the the RM. Even with the microphone concealed under fabric, the tone will still reach the microphone. A remote control system using an IR (infrared) signal would require a line of sight between remote module and transmitter.

**Input gain** is adjusted by setting the desired value on the LCD on the RM in the same manner as it is adjusted on the transmitter. A single pushbutton press and a brief tone burst then transfers the setting to the transmitter.

**Frequency** is adjusted in the same manner, with the options of setting it directly by hex switch code or adjusting it by block and frequency in MHz.

The **Lock** and **Unlock** functions on SM Series transmitters may be used to safeguard the settings and prevent



accidental adjustment. When Lock mode is enabled, the switches on the transmitter control panel will not operate. The only way to unlock the controls with the transmitter itself is to remove the battery. The RM can be used to unlock or lock the transmitter controls with a brief dweedle tone while the transmitter remains in position.

The **Sleep** mode on the SM Series transmitters extends battery life during idle conditions. This is very useful when lengthy preparations are necessary or with extensive costuming. The transmitter and microphone can be placed and concealed early in the process and the transmitter then put to sleep with the RM, which reduces power consumption by a factor of 5. When the production is ready to start, a quick dweedle tone wakes up the transmitter and normal operation resumes.

The life of the single AA battery that powers the RM itself is extremely long. A lithium AA battery may run the unit for several years depending upon how often the unit is used, how loud the tone is played and storage conditions.

The RM is packaged in a machined aluminum housing with a rugged corrosion-resistant finish like the SM Series transmitters. A membrane switch panel helps protect the LCD and internal circuits from moisture and dust.



*The RM is supplied with a quick-release lanyard.*

## Frequency Tuning Range

RF-intense multichannel and mobile venues must have a broad selection of frequencies available to alleviate interference problems, especially with the emergence of DTV telecasts. 256 frequencies are selectable in 100kHz steps across the 25.6MHz tuning range of each frequency block. Nine different blocks are available.

## Battery Compartment

AA battery technology has advanced significantly in recent years, with a variety of high capacity dry cell and rechargeable formats. SM Series transmitters and the RM remote module are designed to take advantage of this new technology and provide extended operating times at high RF power.

The battery door rotates to open and close on both single and dual battery models. A knurled knob is tightened to maintain pressure on the battery contacts.



## Specifications

Note: Some specifications apply only when the transmitter is operating in the 400 Series mode.

<b>Operating Frequencies (MHz):</b>	Block 21: 537.600 - 563.100 Block 22: 563.200 - 588.700 Block 23: 588.800 - 607.900 614.100 - 614.300 Block 24: 614.400 - 639.900 Block 25: 640.000 - 665.500 Block 26: 665.600 - 691.100 Block 27: 691.200 - 716.700 Block 28: 716.800 - 742.300 Block 29: 742.400 - 767.900
<b>Frequency Range:</b>	256 frequencies in 100kHz steps for each 25.5MHz wide block
<b>Channel Spacing:</b>	100 kHz
<b>RF Power output:</b>	SM: 100mW (nominal) SMD: 100mW (nominal) SMQ: 250mW (nominal)
<b>Compatibility Modes (6):</b>	Digital Hybrid Wireless™ (400 Series), 200 Series, 100 Series, IFB, Mode 3*, Mode 6* (*other analog brands)
<b>Pilot tone:</b>	25 to 32kHz; 5kHz deviation; unique pilot tone frequency for each selected carrier frequency (400 Series mode)
<b>Frequency stability:</b>	± 0.002%
<b>Deviation:</b>	± 75kHz (max) (400 Series mode)
<b>Spurious radiation:</b>	60dB below carrier
<b>Equivalent input noise:</b>	-125dBV, A-weighted
<b>Input level:</b>	
<b>If wired for dynamic mic:</b>	0.5mV to 50mV before limiting. Greater than 1V with limiting
<b>If wired for electret lavalier:</b>	1.7uA to 170uA before limiting. Greater than 5000uA (5mA) with limiting
<b>Line Level Input:</b>	5.0mV to 500mV (0.5V) before limiting. Greater than 15V with limiting
<b>Input impedance:</b>	
<b>Dynamic Mic:</b>	300 Ohms
<b>Electret Lavalier:</b>	Virtual ground with servo-adjusted constant voltage bias
<b>Line Level:</b>	2.7k Ohms

### Bias Voltages:

- Fixed 5V at up to 5mA (pin 2)
- Selectable 2V or 4V (pin 3) for any electret lavalier microphone using jumpers in the connector

### Input limiter:

Soft limiter; 30dB range

### Gain control range:

44dB; panel mounted membrane switches

### Modulation indicators:

Dual bicolor LEDs indicate modulation of -20, -10, 0, +10dB referenced to full modulation.

### Audio Performance:

#### Frequency Response:

35 Hz to 20 kHz, +/- 1 dB (The audio is deliberately rolled off at 70 Hz using an 18 dB/octave filter. This filter cannot be disabled.)

### Signal to Noise Ratio (dB): (Overall System 400 Series Mode)

	SmartNR	No Limiting	w/Limiting
OFF		103.5	108.0
NORMAL		107.0	111.5
FULL		108.5	113.0

Note: The dual envelope "soft" limiter provides exceptionally good handling of transients using variable attack and release time constants. Once activated, the limiter compresses 30+dB of transmitter input range into 4.5dB of receiver output range, thus reducing the measured figure for SNR without limiting by 4.5dB.

### THD:

0.2% (typical), (400 Series mode)

### Audio Input Jack:

Switchcraft 5-pin locking (TA5)

### Antenna:

Flexible, unbreakable steel cable

### Battery:

1.5 Volt AA lithium or rechargeable NiMH recommended

### Battery Life:

SM:	1.5 hours (alkaline); 5.5 hours (lithium), 4 hours with 2500mAh NiMH
SMD:	5.75 hours (alkaline); 14.25 hours (lithium), 8.5 hours with 2500mAh NiMH
SMQ:	1.75 hours (alkaline); 7.5 hours (lithium), 5 hours with 2500mAh NiMH
Weight:	RM: 2.3 oz.. (65.8 grams) with lithium battery SM: 2.7 oz.. (75.9 grams) with lithium battery SMD/Q: 3.7 oz.. (105 grams) with lithium batteries

### Overall Dimensions:

SM/RM:	2.3 x 1.8 x 0.64 inches (not including microphone/lanyard) 58 x 46 x 16 mm (not including microphone/lanyard)
SMD/Q:	2.3 x 2.4 x 0.64 inches (not including microphone) 58 x 60 x 16 mm (not including microphone)

Emission Designator: 180KF3E

