

LM

Digital Hybrid UHF Belt Pack Transmitter

TECHNICAL DATA



Feature Highlights

- Digital Hybrid Wireless™ technology (US patent pending)
- Multi-mode compatibility with Digital Hybrid and analog receivers
- 256 synthesized frequencies
- Greater than 50mW output power
- DSP based pilot-tone signal
- DSP controlled, dual envelope input limiter
- 5-pin input jack for mic and line level signals
- Rugged machined aluminum construction

Digital Hybrid Wireless™ is a revolutionary new design that combines digital audio with an analog FM radio link to provide outstanding audio quality and the extended operating range of the finest analog wireless systems.

The design overcomes channel noise in a dramatically new way, digitally encoding the audio in the transmitter and decoding it in the receiver, yet still sending the encoded information via an analog FM wireless link. This proprietary algorithm is not a digital implementation of an analog compandor. Instead, it is a technique which can be accomplished only in the digital domain, even though the audio inputs and outputs are analog signals. The process eliminates a compandor and its artifacts.

The LM belt-pack transmitter implements the latest digital/analog hybrid technique in a classic Lectro belt-pack transmitter. A 5-pin input jack provides taps for low impedance dynamic mics, electret lavalier mics with positive or negative bias and line level inputs. Input gain is adjustable over a 43 dB range to perfectly match the audio input level for optimum modulation, minimum distortion and maximum signal to noise ratio. Input levels are accurately indicated by two LEDs on the control panel.

The input amplifier uses an ultra low noise op-amp for quiet operation. It is gain controlled with a wide range dual envelope input limiter which cleanly limits input signal peaks over 30 dB above full modulation. A 24-bit A-D converter in the input section digitizes the audio, followed by filters to remove supersonic audio above 21 kHz. The resulting signal is then encoded with a proprietary algorithm to produce an analog data signal for RF transmission. The RF transmission is an aggressively optimized FM system with +/-75 kHz wide deviation for a high signal to noise ratio. The overall system delivers full bandwidth audio frequency response up to 20 kHz.

The LM is powered by a single 9 V battery and provides a over 50 mW output for extended operating range. The housing and belt-clip are machined aluminum, powder coated and laser engraved for ruggedness and legibility.



Two 16-position rotary switches adjust the operating frequency of the transmitter over a 25.6 MHz bandwidth in 100 kHz steps.



A removable low profile stainless steel wire belt clip is provided for conventional use. Remove the belt clip for use in pouches or concealment in costumes or clothing.

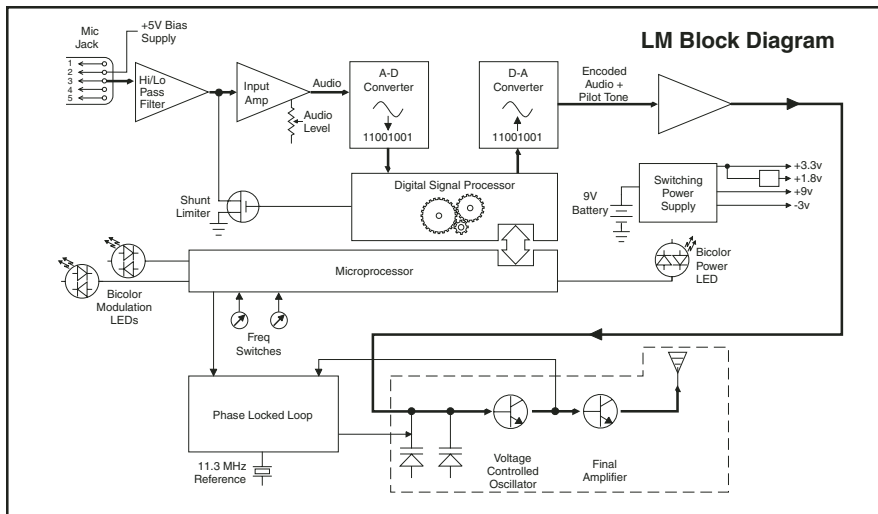

Operating Frequencies (MHz):

Block 21	537.600 - 563.100
Block 22	563.200 - 588.700
Block 23	588.800 - 607.900; 614.100 - 614.300
Block 24	614.400 - 639.900
Block 25	640.000 - 665.500
Block 26	665.600 - 691.100
Block 27	691.200 - 716.700
Block 28	716.800 - 742.300
Block 29	742.400 - 767.900
Block 30	768.000 - 793.500 (export)
Block 31	793.600 - 805.600 (export)

The LM transmitter is constructed of machined aluminum to provide the ruggedness needed in the field. The extruded housing is finished with electrostatic powder coat, and the control panel and battery door are finished with anodized surfaces. Nomenclature is laser etched into the finishes for lasting legibility.



The machined aluminum battery door is hinged to the housing. Battery contacts automatically adjust to a wide variety of alkaline and lithium 9 V batteries.

Specifications

Frequency selection:	256 frequencies in 100 kHz steps
RF Power output:	50 mW (nominal)
Pilot tone:	25 to 32 kHz; 5 kHz deviation
Frequency stability:	± 0.002%
Deviation:	± 75 kHz (max)
Spurious radiation:	60 dB below carrier
Equivalent input noise:	-120 dBV (A-weighted)
Input level:	Nominal 2 mV to 300 mV, before limiting. Greater than 1V maximum, with limiting.
Input impedance:	2k Ohm
Input limiter:	Dual envelope "soft" limiter; greater than 30 dB range
<i>Note</i>	
<i>The dual envelope "soft" limiter provides exceptionally good handling of transients using variable attack and release time constants.</i>	
Gain control range:	43 dB; semi-log rotary control
Modulation indicators:	Dual bicolor LEDs indicate modulation of -20, -10, 0, +10dB referenced to full modulation
Audio Performance (overall system with UCR411a receiver):	
Frequency Response:	90 Hz to 20 kHz (+/-1dB)
THD:	0.2% (typical)
SNR at receiver output:	

	SmartNR	No Limiting	W/ Limiting
OFF		103.5	108.0
NORMAL		107.0	111.5
FULL		108.5	113.0

Note
The onset of limiting in the design begins below full modulation, which reduces the measured figure for SNR without limiting by 4.5 dB.

Low frequency roll-off:	-12 dB/octave; 70 Hz (The transmitter is deliberately rolled off at 70 Hz to reduce the undesired effects of lower frequencies.)
Controls:	<ul style="list-style-type: none"> • Two position "ON-OFF" power switch • Audio input gain control on front panel • Two 16-position rotary switches adjust transmitter frequency
Audio Input Jack:	Switchcraft 5-pin locking (TA5F)
Antenna:	Galvanized steel, flexible wire
Battery:	Precision compartment auto-adjusts to accept any known alkaline 9 Volt battery. (We've tried 243 different ones.)
Battery Life:	6 hours (alkaline); 13 hours (lithium)
Weight:	6.3 ounces, including lithium 9 V battery and antenna
Dimensions:	3.1 x 2.4 x .75 inches

Emission Designator: 180KF3E

LM-TD-12/04