

LPDA Antennas

ALP500

Economical design ideal for fixed applications



ALP620

Skeletal design for decreased wind loading



ALP650 Series

Onboard amplifier ideal for long cable runs, phantom powered from Venue, UMC16 or Bias T



The ALP Series antennas are a Log Periodic Dipole Array (LPDA) design that provides a useful directional pattern over a broad frequency bandwidth. Many “gain antennas” (those designs with a directional pattern) are limited in bandwidth, making them awkward for use in multi-channel wireless systems and with frequency agile wireless systems. With VSWR below 2:1 from 450 to 862 MHz, the broad bandwidth of the ALP Series covers a broad section of the band used for Lectrosonics wireless microphone and IFB systems, yet still provides the directional pattern needed to cover long distances.

All ALP Series antennas are constructed of 1/8" FR4 fiberglass board and are extremely rugged. The ALP620 and ALP650 antennas include a protective cover over the BNC connector, making them suited for field production, while the more economical ALP500 is better suited for indoor installation. The perforated body of the ALP620 makes it highly resistant to wind loading outdoors. The ALP650 models are “receive only” models, featuring a built-in amplifier with adjustable gain for use with long coaxial cable runs and/or RF splitters.

The antennas can be mounted horizontally or vertically by removing four screws and repositioning the mounting block. This helps to position the antenna away from nearby reflective surfaces to preserve more of the natural pattern of the LPDA design.

Versatile Mounting Block

The mounting block on all ALP Series antennas can accept three common sizes of threads:

- 1/4"-20 (tripod mount)
- 3/8"-16 (pro tripod mount)
- 5/8"-27 (mic stand)

A 3/8"-16 stud (Part #28769) is included with all ALP Series antennas.

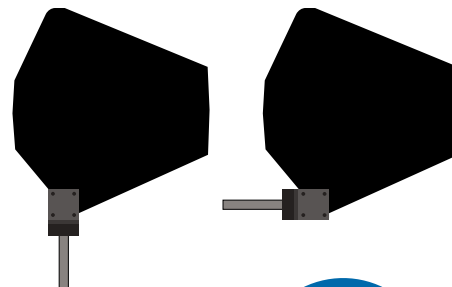

The mounting block can be rotated to allow horizontal or vertical mounting

CE1313

Applies to ALP650 Series only.

Phantom Power

The amplifier in the APL650 must be powered by DC (“phantom power”) supplied through the coaxial cable connected to the antenna. This can be accomplished with the BiasT, Venue receiver or UMC16B multicoupler.

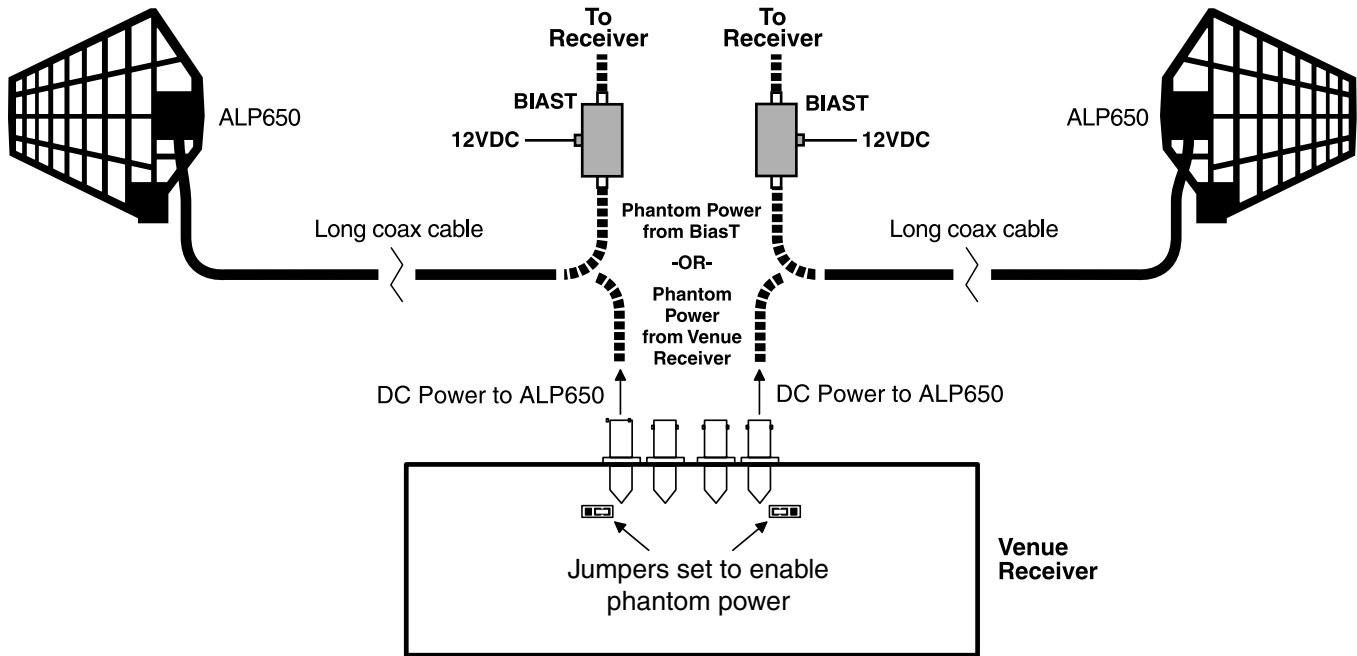

UMC16B Jumpers

This 8-channel diversity multicoupler can power the APL650 antenna by enabling DC power with jumpers located on the circuit board.

Disconnect power from the unit and remove the top cover. Install the jumpers so that both pins make contact with the socket on the circuit board as shown below.

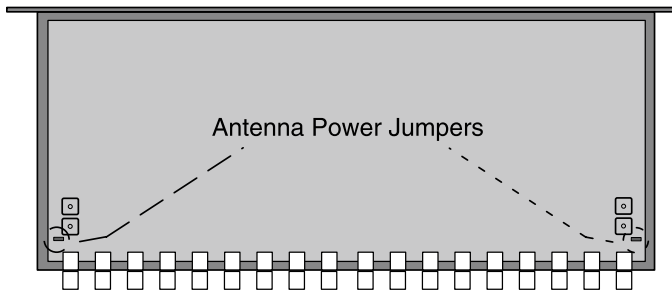

To enable phantom power

To disable phantom power

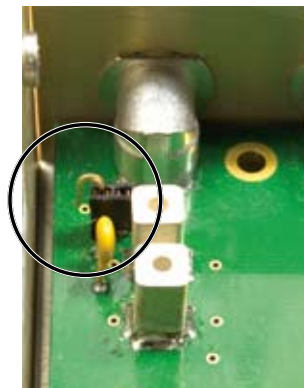
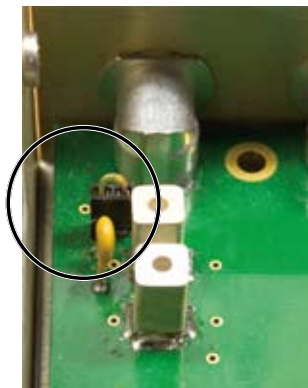

Venue Receiver Jumpers

All versions of the Venue receiver provide jumpers on the circuit board near the BNC jacks to enable or disable the phantom power.

Disconnect power from the receiver and remove the top cover. Install both jumpers towards the center of the receiver to enable phantom power.

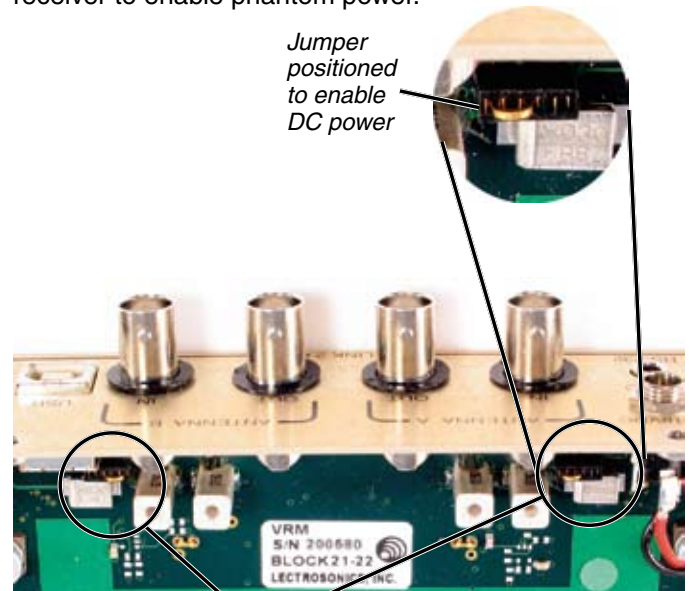

Jumper locations in the Venue Receiver



Store other jumpers here

Adjusting Gain on the ALP650 Amplifier

In cases where the antenna is feeding a long coaxial cable run and/or a splitter, additional gain is generally needed. The goal is to compensate for the loss through the cabling and deliver a signal level equivalent to connecting the antenna directly to the receiver. Too much gain adds unnecessary noise and some risk of increasing IM (intermodulation) in the receiver. Too little gain runs the risk of dropouts in the reception.

Three jumpers are provided to adjust the gain from the built-in amplifier to the desired value:

Jumper Value	Attenuation	Resulting Gain
0	0 dB	12 dB
-4	4 dB	8 dB
-7	7 dB	5 dB

Add up the loss caused by long coaxial cable runs, antenna splitters, etc. and set the gain as closely as possible to the total loss. For example, consider a 4-way passive splitter such as the ZFSC41 with 6 db of loss at each output and a coaxial cable such as the ARG15 with 2 db of loss, for a total loss of 8 dB. In this case, the amplifier should be used with the 4 dB attenuator to produce the needed 8 dB of gain (12 - 4 = 8). One of the jumpers must be in the active position at all times.

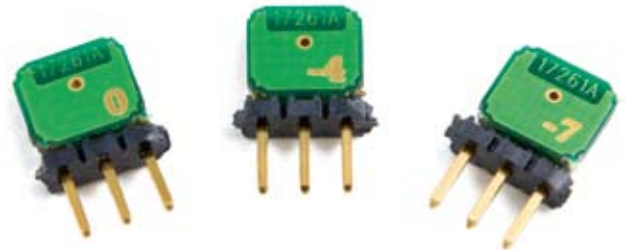

Optional Mounting Adapter Kit

Threaded adapter for standard lighting clamps. 1/2" diameter x 6 inch long. 3/8"-16 thread - both ends.

Microphone stand adapter, 1 1/2" long. 5/8"-27 thread on one end, with 3/8"-16 thread in other end. Knurled finish.

Threaded adapter for photo/video tripod mounting. 1/2" diameter x 1 3/4" long. 3/8"-16 thread on one end, 1/4"-20 on the other.

1/4" - 20 threaded adapter



Optional Accessories

Mini-Circuits passive splitters:

Model	Loss:
ZSC24 (2-way)	3 dB
ZSC41 (4-way)	6 dB
ZSC843 (8-way)	9 dB

Coaxial Cables:

Model	Loss:
ARG2 (2 ft. RG174)	1 dB
ARG15 (15 ft. RG174)	2 dB
ARG25 (25 ft. Belden 9913F)	1.9 dB
ARG50 (50 ft. Belden 9913F)	2.8 dB
ARG100 (100 ft. Belden 9913F)	4.6 dB

Orientation

A wireless transmitter antenna is generally oriented vertically, therefore, the ALP should also be oriented vertically. The transmitter antenna should be parallel with the plane of the ALP antenna as depicted below.

Typical Horizontal Pattern

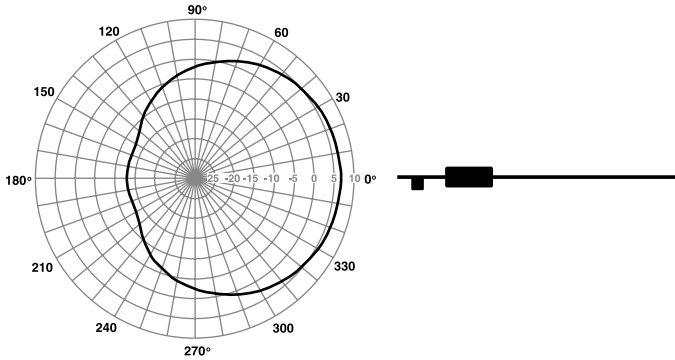

Typical Vertical Pattern

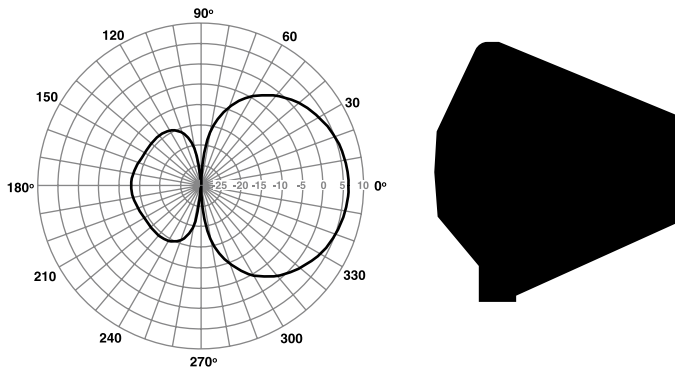

The ALP650 antenna has been tested and found to comply with the limits for a Class B digital device, pursuant to Part 15 of the FCC Rules. These limits are designed to provide reasonable protection against harmful interference in a residential installation. However, there is no guarantee that interference will not occur in a particular installation. The antenna generates, uses and can radiate radio frequency energy and, if not installed and used in accordance with the instructions, may cause interference to radio receivers. Changes or modifications to this equipment not expressly approved by Lectrosonics, Inc. could void the user's authority to operate it.

Specifications

ALP500, ALP620

Pattern Gain:	+7dBi (isotropic) +4dBd (over dipole)
Range:	450-862 MHz
Weight:	ALP500: 14.2 oz. ALP620: 9.4 oz. ALP650/L/M/H: 12 oz.
Connector:	50 Ohm BNC
Dimensions:	12" high x 10.5" deep x 1.5" wide (ALP650 without mounting hardware)

ALP650 Series with RF amplifier

Pattern Gain:	+7dBi (isotropic) +4dBd (over dipole)
Passband:	ALP650L 470.000 - 692.000 MHz ALP650 537.000 - 767.000 MHz ALP650L/E (RoHS compliant) 470.000 - 692.000 MHz ALP650M/E (RoHS compliant) 537.000 - 768.000 MHz ALP650H/E (RoHS compliant) 640.000 - 862.000 MHz
RF Gain:	+12 dB with 0dB attenuator +8 dB with 4dB attenuator +5 dB with 7dB attenuator
Third Order Intercept:	+27 dBm @ input (+41 dBm output)
Weight:	12 oz. (all versions)

All Models

Power Requirements:	8V to 16V DC at the input jack; auto reset poly fuse protection circuit; constant power switching supply • 8V DC (125 to 145 mA) • 12V DC (83 to 106 mA) • 14.4V DC (69 to 89 mA) • 16V DC (60 to 80 mA)
Phantom Powering:	DC voltage supplied via coaxial cable by UMC16B, VRM input jack or BIAS-T power inserter (70 to 80 mA)
Power Consumption:	1 Watt nominal (switching regulator)

If this equipment does cause harmful interference to radio or television reception, which can be determined by turning the equipment off and on, the user is encouraged to try to correct the interference by one or more of the following measures:

- Reorient or relocate the receiving antenna
- Increase the separation between the equipment and receiver
- Connect the equipment into an outlet on a circuit different from that which the receiver is connected
- Consult the dealer or an experienced radio/TV technician for help

