

# **TH2**

## **DIGITAL TELEPHONE HYBRID**

---

---

### **OPERATING INSTRUCTIONS and trouble-shooting guide**

---

---

**LECTROSONICS, INC.**

Rio Rancho, NM

## INTRODUCTION

The TH2 Digital Hybrid is part of the LecNet™ family of audio products. The TH2 works with any standard two wire telephone system, to provide a convenient and inexpensive means of using any sound system for teleconferencing. This product is microprocessor controlled, with a powerful Digital Signal Processor (DSP) actively adjusting the line balance to achieve maximum transmit and receive signal separation. In addition, echo suppression based on Lectrosonics patented Adaptive Proportional Gain algorithm (U. S. Patents No. 5402500 and 5414776) minimizes acoustic echo while maintaining virtually full-duplex operation. The TH2 can be setup manually or with an IBM compatible PC in the PC Remote mode. Manual setup is accomplished by adjusting three trimmer potentiometers and a set of dip switches. Four push-buttons and a wired remote control port provide a convenient way to control the operation of the TH2 locally or remotely.

---

## TABLE OF CONTENTS

INTRODUCTION .....	2
FCC PART 68 COMPLIANCE .....	3
GENERAL TECHNICAL DESCRIPTION .....	4
INSTALLATION .....	5
FRONT PANEL DESCRIPTION .....	7
DIP SWITCH OPTIONS .....	7
REAR PANEL DESCRIPTION .....	8
OPERATING INSTRUCTIONS .....	9
TH2/AM8 SYSTEM SETUP PROCEDURE .....	10
TROUBLESHOOTING .....	11
SERIAL CABLE WIRING DIAGRAM .....	12
AMX CABLE WIRING DIAGRAM .....	12
AMX Programming Notes .....	12
SERIAL PORT SOFTWARE COMMANDS .....	13
SPECIFICATIONS .....	16
ACCESSORIES .....	16
SERVICE AND REPAIR .....	17
RETURNING UNITS FOR REPAIR .....	17
WARRANTY .....	Back cover

## **FCC PART 68 COMPLIANCE**

This equipment complies with Part 68 of the FCC rules. On the rear panel of this equipment is a label that contains, among other information, the FCC registration number and ringer equivalence number (REN) for this equipment. If requested, this information must be provided to the telephone company.

This equipment uses the following USOC jacks: RJ11C

The REN is used to determine the quantity of devices which may be connected to the telephone line. Excessive REN's on the telephone line may result in the devices not ringing in response to an incoming call. In most, but not all areas, the sum of the REN's should not exceed five (5.0). To be certain of the number of the devices that may be connected to the line, as determined by the total REN's, contact the telephone company to determine the maximum REN for the calling area.

If this equipment causes harm to the telephone network, the telephone company will notify you in advance that temporary discontinuance of service may be required. If advance notice isn't practical, the telephone company will notify the customer as soon as possible. Also, you will be advised of your rights to file a complaint with the FCC if you believe it is necessary.

The telephone company may make changes in its facilities, equipment, operations, or procedures that could affect the operation of the equipment. If this happens, the telephone company will provide advance notice in order for you to make the necessary modifications in order to maintain uninterrupted service.

If trouble is experienced with this equipment, please contact Lectrosonics, Inc. at (800) 821-1121 for repair and/or warranty information. If the trouble is causing harm to the telephone network, the telephone company may request you remove the equipment from the network until the problem is resolved.

The following repairs can be done by the customer: No user serviceable parts inside.

This equipment cannot be used on telephone company-provided coin service. Connection to Party Line Service is subject to state tariffs.

## GENERAL TECHNICAL DESCRIPTION

The TH2 is built around a powerful DSP which performs all internal calculations using 24 bits, providing an internal dynamic range of 144dB. The DSP implements both the transmit/receive signal separation, as well as a sophisticated echo suppression algorithm. The Lectrosonics Adaptive Proportional Gain algorithm (US patent #5,414,776 & #5,402,500) used for echo suppression dynamically varies the transmit and receive path gain in response to the signal level present in both paths. This helps prevent retransmission of a received signal caused by acoustic coupling between near-end system loudspeakers and microphones. Because no abrupt gain changes are made, the perceived effect is a full duplex conversation.

The TH2 is fully interfaced with the AM8 automatic mixer in that it participates in the auto mixing algorithm just like another microphone. The transmit (or near-end) signal is typically received from the Lectrosonics AM8 Automatic Mixer via the TH2 Expansion Out jack. When the near-end transmit signal is coming from any other line level source, it is connected to the TH2 via the Local In/Out port (balanced or unbalanced). The Transmit Level control allows adjustment of the transmit signal which is passed through a very fast attack limiter prior to being digitized by the 13 bit A/D converter. The transmit output signal is converted back to an analog signal by the 13 bit D/A converter, buffered, and output to the phone line coupling transformer.

The far-end signal is received from the phone line coupling transformer, buffered, digitized by the 13 bit A/D converter and processed in the DSP chip. It is then converted back to an analog signal by the 13 bit D/A converter, and output either to the Expansion or Local Out port (balanced or unbalanced). The Receive Level control allows adjustment of the receive signal, while Volume Up/Dn pushbuttons regulate the received volume. LEDs indicate level changes and show when limits are reached. Volume adjustment range is set with the combination of two dip switches from the front panel. The Connect push-button connects the TH2 to the phone line, while the Privacy push-button mutes the transmit path of the TH2, allowing private conversation to take place.

Because of impedance mismatches between the transmit output driver and the transformer and phone line, some of the transmit signal recirculates through to the receive path. In a normal telephone handset, this recirculated transmit signal is known as a "sidetone." In teleconferencing applications, however, this sidetone signal can cause feedback or loss of intelligibility. For this reason, the DSP is programmed to remove any artifacts of the transmit signal from the receive signal. The Mix Out connector provides an unbalanced output signal for recording purposes (in the Expansion or Local mode) consisting of a mix of the transmit and receive signals.

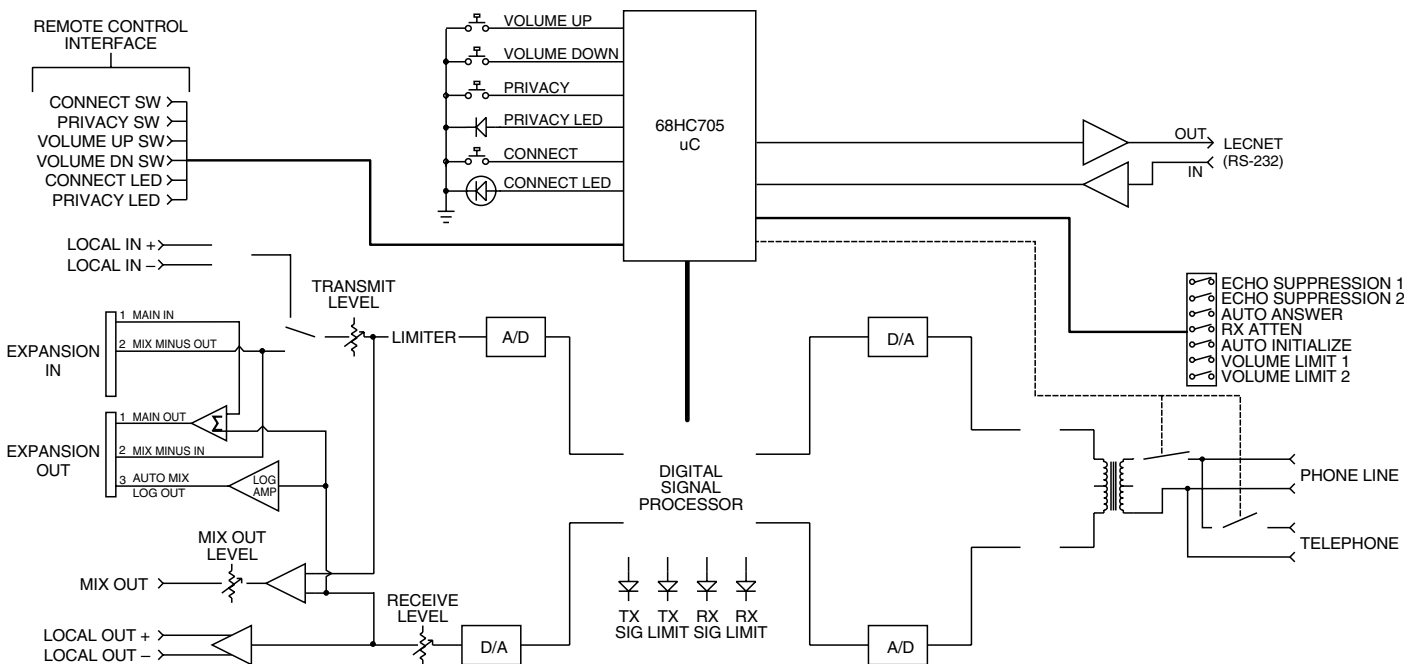

Figure 1 - TH2 Block Diagram

# INSTALLATION

## WITH THE AM8 AUTOMATIC MIXER

(Figure 2)

Used with the Lectrosonics AM8 automatic mixer, the interconnections to the TH2 are very simple. Set the Local Expan switch on the TH2 to the Expan position. Set the Master/Slave switch on the AM8 to the Master position. Plug in the supplied 8-pin mini DIN cable as shown in Figure 2. The TH2 will receive signals from the AM8 and send signals to the AM8 via this single connecting cable.

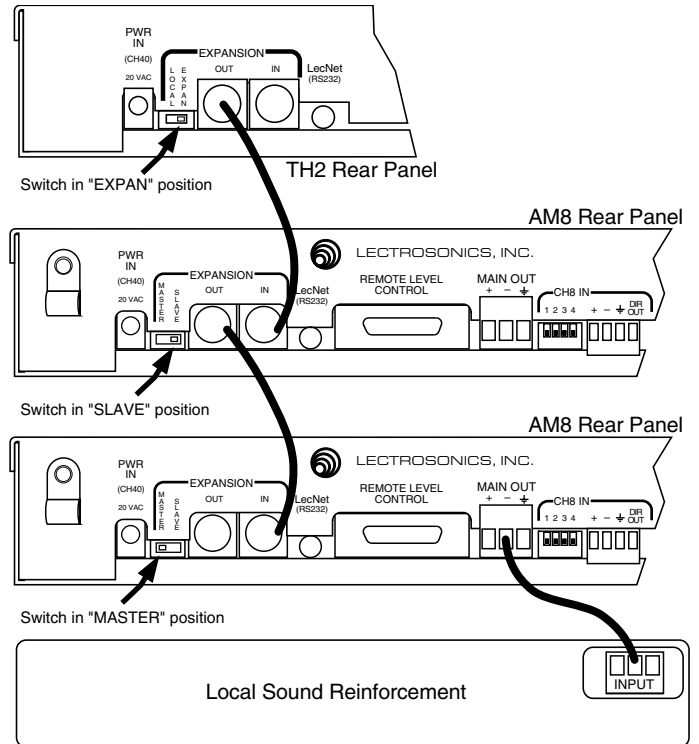

Figure 2 - TH2 & AM8 Configuration

## BALANCED INTERCONNECTION WITH NON-LECTROSONICS MIXERS

(Figure 3)

For use with any non- Lectrosonics microphone mixer and sound system, the Local/Expan switch on the TH2 is set to the Local position. The cable connections are made as shown in Figure 3 to maintain a balanced wiring configuration. Note that the TH2 output signal at the Local Out jack must be connected to the sound system outside of the mixer that feeds the TH2. This typically requires the use of a separate mixer ahead of the sound system amplifier as illustrated in Figure 3.

An Unbalanced configuration is also possible using these same jacks. For this configuration, leave the (-) unconnected on the TH2 Local In/Out jack and use the (+) terminal for signal hot.

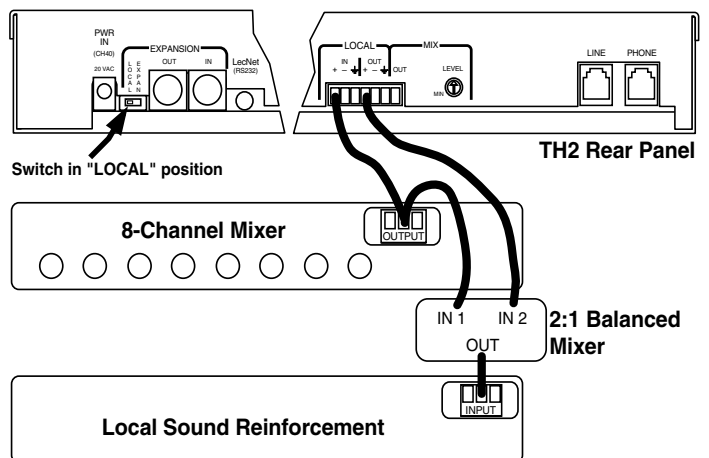

Figure 3 - TH2 & Single Bus mixer Configuration with Balanced Outputs

**OPTIONAL UNBALANCED INTERCONNECTION WITH NON-LECTROSONICS MIXERS**

(Figure 4)

A simple method of mixing the incoming phone line signal with the local microphone mixer output is illustrated in Figure 4. This is an unbalanced configuration best suited to short cable runs, such as with components rack mounted next to each other. This configuration simplifies the wiring connections and eliminates the need to install an external mixer ahead of the sound reinforcement system.

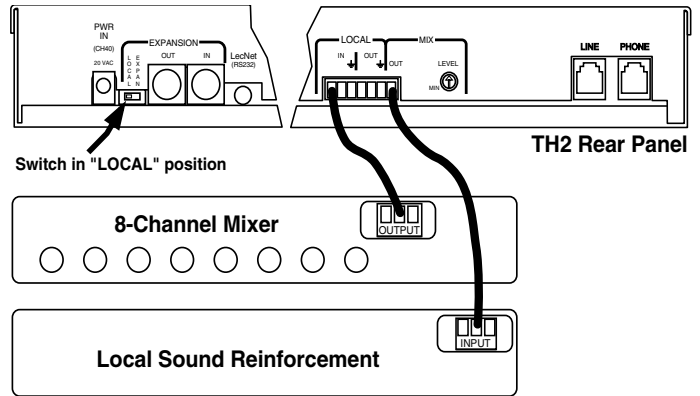

Figure 4 - TH2 & Single Bus Mixer Configuration with Unbalanced Outputs

**SIMULTANEOUS 2-WIRE/4-WIRE CONVERSION FOR 3-SITE CONFERRING BRIDGING**

(Figure 5)

The TA1 Line Level Adapter is designed for connecting an Audio/Video Teleconferencing Hybrid to the Lectrosonics AM8 automatic mixer.

With the AUTO MIX switch in the "ON" position, the video codec (or other audio source) will participate in the automatic mixing algorithm applied by the AM8 mixer. An incoming signal from the far end of the telephone or ISDN line will attenuate the gain on the local microphones, reducing or eliminating acoustical coupling between microphones and loudspeakers that could cause a feedback loop.

Used with the AM8 mixer and TH2 telephone hybrid, 3-site bridging is accomplished with the TA1 without the need for any other mixing or routing devices.

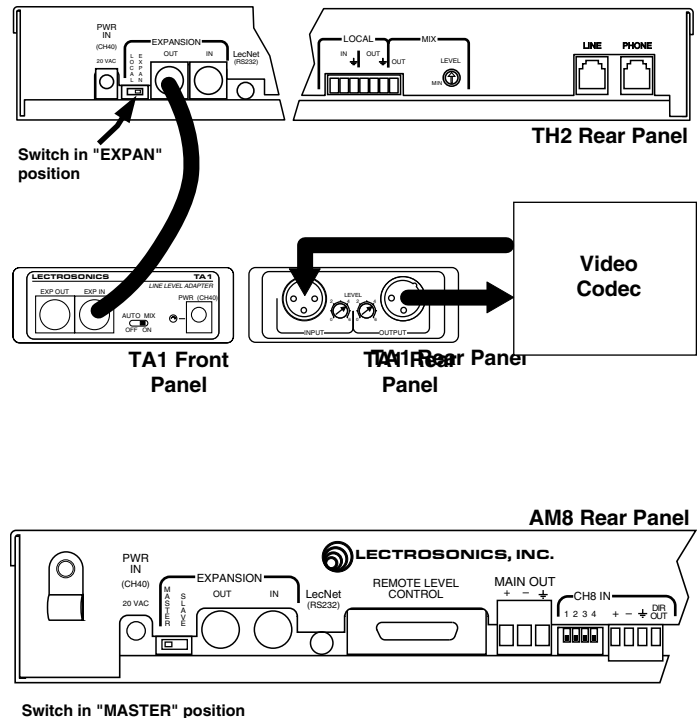

Figure 5 - 3-Site Conferencing Bridging

## FRONT PANEL DESCRIPTION



Figure 6 - TH2 Front Panel

**POWER** - Turns the TH2 On/Off. After the power is turned on, all LEDs, with the exception of the Privacy LED, will turn ON momentarily.

**RECEIVE LEVEL** - Adjusts the receive volume level. The SIG LED next to this potentiometer indicates the presence of receive signal, and the LIM LED indicates overload in the receive channel.

**VOLUME UP/DOWN** - Adjusts the receive audio level. Operates in parallel to the wired remote Volume Up/Down buttons. The range of adjustment is set by the Volume Limit dipswitch settings. Note that the Connect LED will flash each time a change in volume (up or down) is made. With the button held in, the flashing will stop when the volume limits are reached. *Note: To reset the unit to factory defaults, hold in the Volume Up and Volume Down buttons while turning on the Power until the LEDs flash. This will set the LecNet software mode to Local. Any saved Dipswitch settings in the LecNet software control panel will be returned to the factory default settings of switch 3 and switch 5 ON.*

**TRANSMIT LEVEL** - Adjusts the transmit volume level. The SIG LED indicates the presence of transmit signal, and the LIM LED indicates overload in the transmit channel.

**PRIVACY** - Mutes the transmitted audio to allow private conversations to take place. The phone connection is maintained.

**CONNECT** - Connects or disconnects the TH2 from the phone line. The Connect button is used to pick up an incoming call or to switch back and forth between the TH2 and a handset.

## DIP SWITCH OPTIONS

**Volume Limit** - Selects the limitation placed on the volume adjustment range. This limitation only affects the front panel Receive Level pushbuttons, or the Receive Level pushbuttons of the wired remote control (if used).

**Auto Initialize** - Selects whether the TH2 will re-initialize every time it connects. If Auto Initialization is On, the far-end listener will hear a short noise burst as the TH2 resets its adaptive filter coefficients. If Auto Initialization is Off, the adaptive filter coefficients stored from the system setup are used. The best performance will be obtained with Auto Initialization turned On.

**RX Atten** - Selects the amount of input signal attenuation. It is usually used in the 0dB position. If the Receive Lim LED is on with the Receive Level pot in the fully counterclockwise position, it is a good indication that the incoming signal from the phone line is too “hot” and that the dip switch should be set to the -10dB position. If the Receive Lim LED does not turn off, please contact the factory for technical assistance.

**Auto Answer** - Selects whether the TH2 will automatically connect if it receives a phone call. Furthermore, it will automatically disconnect the TH2 when the far-end party hangs up if the local PBX supports loop reversal on hangup. When the TH2 automatically disconnects, a loop reversal impulse (approximately 10 seconds after the hangup) could be heard from the local sound reinforcement system.

**Echo Suppression** - Selects the amount of echo suppression used. Auto is the normal setting. Auto uses the least echo suppression possible to achieve acceptable performance. Use the other settings as necessary if too much of the received signal is acoustically coupled back to the transmit signal.

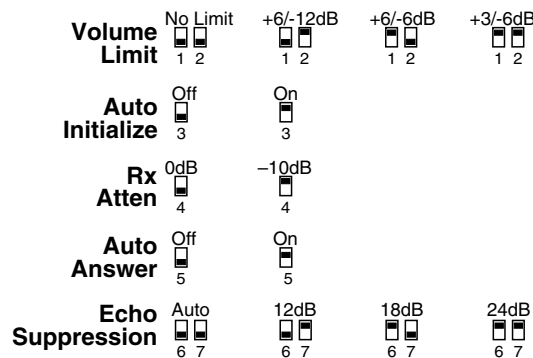
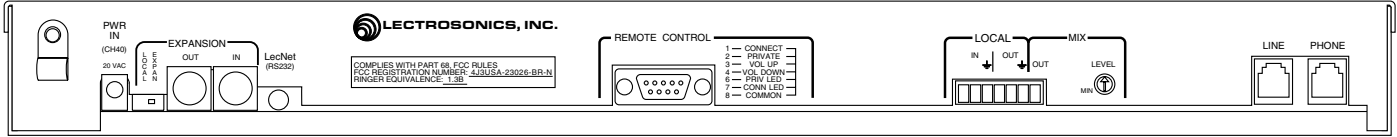

Figure 7 - TH2 Dip Switch Settings

## REAR PANEL DESCRIPTION



*Figure 8 - TH2 Rear Panel*

**PWR IN** - connects to the CH40 power supply supplied with the unit.

**LOCAL/EXPAN SWITCH** - Sets the TH2 for use in conjunction with either the AM8 (expansion mode) or any other line level Input/Output (local mode).

**EXPANSION IN/OUT** - Allows the TH2 to be connected to the Automatic Mixer AM8 and other LecNet devices. With this connection the Receive signal is automatically mixed with other microphones using Lectrosonics' unique and very effective Adaptive Level Proportional mixing algorithm\* for local sound reinforcement purposes. Note: The TH2 must be connected directly to the AM8. Other LecNet devices must be connected to the TH2 Expansion In connector.

**LECTNET (RS232) SERIAL PORT** - Provides access to and remote control of some of the operational features of the TH2. This port is compatible with the serial port of a PC, AMX touch screen, or any other controller with the standard RS232 type serial port. Refer to Serial Port Software Commands on page 13.

**(WIRED) REMOTE CONTROL** - Allows the Connect, Privacy and Volume Up/Down momentary pushbuttons (and indicator LEDs) to be operated from a remote location. Figure 9 shows the connection diagram to the 9 pin D-Sub Remote Control connector.

**LOCAL IN(+), IN(-)** - Accepts a line level balanced or unbalanced transmit input signal. Typically this input is driven from the output of a microphone mixer.

**LOCAL OUT(+), OUT(-)** - Outputs the received audio signal into a sound reinforcement system.

**MIX OUT** - Provides an unbalanced signal consisting of a mix of the transmit and receive signals. Generally used for recording both sides of the conversation.

**MIX OUT LEVEL** - Controls the audio level of the Mix Output.

**LINE** - Accepts a standard two wire telephone line on an RJ-11 style connector.

**PHONE** - Accepts a standard RJ-11 style connector to enable a telephone to be used in conjunction with the TH2.

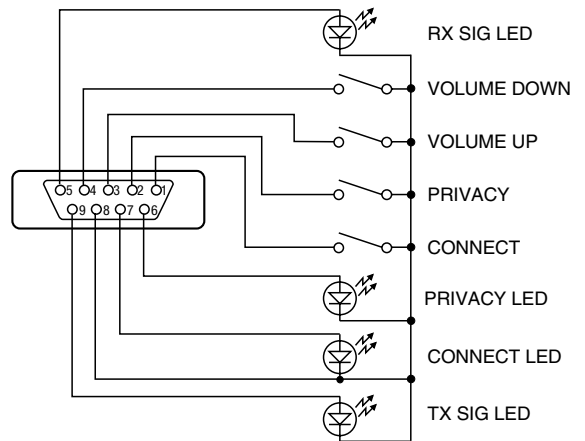

*Figure 9 - TH2 Remote Control Connector*



## OPERATING INSTRUCTIONS

Setup of the TH2 consists of choosing the front panel dip switch options, setting transmit and receive levels located at the front panel, and connecting the Input/Output in the proper configuration. Using the LecNet™ Control is covered in the Serial Port Hardware and Software sections of this manual. When the power is turned on to the TH2 the LEDs, with the exception of the Privacy LED, will momentarily turn On.

Note: To reset the unit to factory defaults, hold in the Volume Up and Volume Down buttons while turning on the Power until the LEDs flash. This will set the LecNet software mode to Local. Any saved Dipswitch settings in the LecNet Software control panel will be returned to the factory default settings of switch 3 and switch 5 ON.

- 1) Connect the CH40 power supply to the PWR IN jack of the TH2.
- 2) Connect the telephone line to the LINE input RJ-11 jack. If a local telephone is to be used in conjunction with the TH2, connect it to the PHONE input RJ-11 jack. Note that to originate calls, a local phone must be connected to the system.
- 3) Connect the audio Input/Output according to the desired configuration either through the Expansion or Local port (refer to the Installation section of this manual paying particular attention to the LOCAL/EXP switch.)
- 4) Set the Transmit Level control and the Receive Level control to the mid position (12 o'clock). Set the Main Output level control on the AM8 to the mid position.

- 5) Set the dipswitch options as desired. Factory settings are:

Echo Suppression:	Auto	Auto Answer:	On
Rx Atten:	0dB	Auto Init:	On
Volume Limit:	No Limit		

- 6) If a local phone is connected, originate a call to a remote site. If no local phone is present, someone at a remote site must call you. If you are the originating site, press the CONNECT button to connect the TH2 to the phone line after the call has been established. If the remote site originates the call, and Auto Answer is On, the TH2 will establish the connection automatically.
- 7) Adjust the receive volume level using the Receive Level control. Then adjust the transmit level using the Transmit Level control, or Main Level on the AM8. If the Receive Lim LED is on with the Receive Level pot in the fully counterclockwise position, it is a good indication that the incoming signal from the phone line is too "hot" and that the Rx Atten dip switch should be set to the 10dB position. If the Receive Lim LED does not turn off, please contact the factory for technical assistance.
- 8) When all volume levels are acceptable, disconnect the call by pressing the CONNECT button again.
- 9) If any limitation on the remote volume control range is desired, set the Volume Limit dip switches accordingly.
- 10) The TH2 revisions 1.1 and higher now include firmware support for the J7 DC Bypass jumper. This jumper can be used to bypass the automatic disconnect circuitry on the TH2. This feature is intended to be used in installations where the TH2 is connected to an outside phone line through a PBX system which does not supply DC battery. By changing the position of the DC Bypass jumper, and by selecting the dipswitch option AUTO ANSWER to OFF, the TH2 will be transferred to fully manual operation. The factory default position is Auto Disconnect.

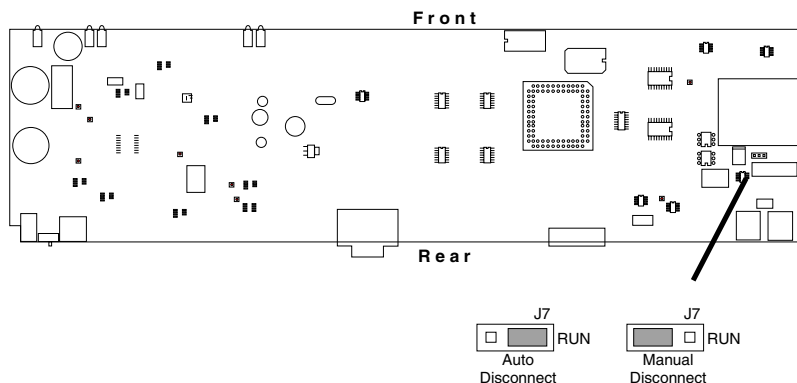

Figure 10 - Location of DC Bypass Jumper

## TH2/AM8 SYSTEM SETUP PROCEDURE

When used in conjunction with one or more AM8's, the following procedure will insure optimum operation. The system architecture provides for algorithm-controlled gain paths that require the signal levels received by the TH2 and the signal levels within the AM8 (microphone or other line level devices) be relatively equal. When this is achieved, a very high quality teleconference results with seamless, near-duplex operation.

The following procedure will serve as a guide to balancing TRANSMIT (near end signal from the AM8) and RECEIVE (far end signal received by the TH2) signal levels without the need for any external test equipment or computer:

### 1) Set the inputs of the AM8 for proper gain.

The first step is to select the appropriate mic preamp gain on the AM8. Most condenser and some wireless mics would use +30dB gain setting, while most dynamic mics or if the mic to talker distance is great would use +50dB gain setting; 0dB gain setting is used for devices capable of producing line level output signals (tape deck, CD player, some wireless mics).

### 2) Adjust the individual CHANNEL LEVEL and MAIN LEVEL controls.

Start with the CHANNEL LEVEL and MAIN LEVEL controls on the AM8 at mid position and have someone talk into one of the mics at a normal operating distance. Switch the COMP/LEVEL to the IN position and set the THRESHOLD trim pot to "-10." Now adjust the input channel level control so that only the right-most three LEDs come on at the loudest peaks in the speaker's voice, while during the normal speech no LEDs should be lit. The proper adjustment of the COMP/LEVEL would cause compressor/leveler action only during the very loud speech or if the participant leans very close to the mic.

If local sound reinforcement is not used in the room, turn the MAIN LEVEL to minimum since this pot will not influence the TRANSMIT signal. If local sound reinforcement is incorporated in the room, adjust the MAIN LEVEL pot and the volume on the power amplifier (PA) to the desired SPL in the room. Check each AM8 input's contribution to the SPL in the room, and re-adjust the CHANNEL LEVEL such that all inputs are approximately at the same SPL in the room. Note that the MAIN LEVEL and PA volume are essentially connected in series, so that if you increase one and decrease the other, the SPL in the room should be about the same.

### 3) Establish an outside call.

The best results are achieved using a Plain Old Telephone System (POTS) line, or using a telephone line simulator such as Teltone TLS-3, or TLS-4. When setting up the TH2, establish a call "off-site" and adjust for the average of several calls since there might be some difference in received levels from one call to another. It is best to avoid calling from an "in-house" extension within the same PBX or KSU, since such a call would typically be 6-10dB louder than an outside call. Furthermore, initially avoid test calls from the bridging service since they are typically 6-10dB quieter than an outside call.

### 4) Adjust the RECEIVE LEVEL trim pot.

Starting from the mid position on the RECEIVE LEVEL trim pot on the TH2, adjust the level so that the incoming call is heard through the local PA system at about the same SPL as the AM8 inputs (mics and line level devices). If local sound reinforcement is not used, adjust the RECEIVE LEVEL to the desired SPL in the room. In both cases, the RECEIVE SIG LED will be lit when far-end signal is received through the TH2.

If the RECEIVE LIM LED is lit, you are clipping the signal either at the output, or internally in the Digital Signal Processor (DSP). Back off on the RECEIVE LEVEL all the way to the minimum - if the LIM LED is not lit, your RECEIVE LEVEL was too high. If the LIM LED is still lit, your phone line signal is "too hot", and you need to switch the RX ATTENUATE dipswitch to -10dB position to prevent DSP internal clipping. After the dipswitch positioning, adjust the RECEIVE LEVEL to the desired SPL in the room.

## 5) Adjust the TRANSMIT LEVEL trim pot.

Starting from the mid position on the TRANSMIT LEVEL trim pot, adjust for the proper TRANSMIT level. The TRANSMIT SIG and LIM LEDs are useful tools to determine the appropriate TRANSMIT LEVEL. Make sure that TRANSMIT SIG is lit when someone speaks into the microphone, but back-off the TRANSMIT LEVEL if TRANSMIT LIM LED lights.

## 6) Fine tune the Lectrosonics system to the room acoustic response.

Sometimes, customer expectations are higher than what the audio teleconferencing system can provide. Every conference room will have a different audio response, and each system can be readjusted to its limits - but you can not achieve better response than that allowed by the positioning of microphones, speakers, and overall acoustic signature of the room. Here, we will attempt to describe some common problems when setting up a teleconferencing system.

**a)** If customer expectation is to have a loud receive signal, some of the sound will eventually be recirculated. You can see this behavior on the front panel of the TH2 when RECEIVE LED and TRANSMIT LED are lit at the same time. To correct this problem, either you have to reduce the microphone CHANNEL LEVEL, reposition the microphones/speakers for different acoustic response of the room, or simply reduce the RECEIVE LEVEL.

**b)** If customer expectation is to have a loud transmit signal, by increasing the TRANSMIT LEVEL, the signal level balance between the transmit and receive inside the DSP is disturbed, potentially causing the TH2 to diverge. You should try to reconverge the DSP filter by 1) lifting up the local phone set, disconnecting the TH2, waiting 2-3 seconds, and than re-connecting the TH2, or 2) re-initializing the digital filter through the software control panel.

# TROUBLESHOOTING

## SYMPTOM

## POSSIBLE CAUSE

**No receive sound from TH2**

- 1) Receive Level control not turned up
- 2) Connect LED not lit (push connect switch)
- 3) Phone line from wall jack to TH2 not connected

**No transmit sound from TH2**

- 1) Transmit Level control not turned up to remote site
- 2) The Privacy LED is lit (push privacy switch)
- 3) The Local/Expan switch is not in the correct position

**Feedback or hollow sound**

- 1) RECEIVE LEVEL control turned up too high.
- 2) Not enough Echo Suppression (increase Echo Suppression)
- 3) Large variations in phone line impedance (set Auto Initialize On), or re-initialize the digital filter.

**Signal degradation when used in conjunction with the bridging service or DTMF cards**

- 1) Re-initialize the digital filter "on the fly" through the software control panel without breaking the telephone connection.

# SERIAL CABLE WIRING DIAGRAM

The serial port on the LecNet device is a minimal RS-232 implementation. The figure shows the wiring diagram to accommodate interconnection with either a 9 or a 25 pin serial port on a PC or other serial device.

## LecNet Device to PC



### Wiring Diagram, 9 Pin D-Sub

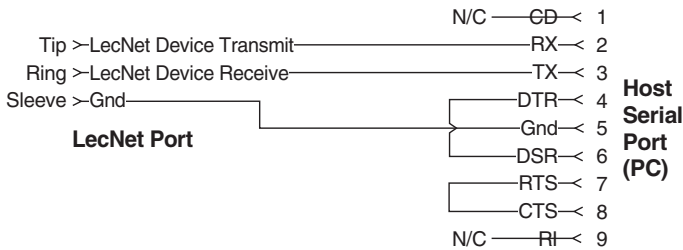

### Wiring Diagram, 25 Pin D-Sub

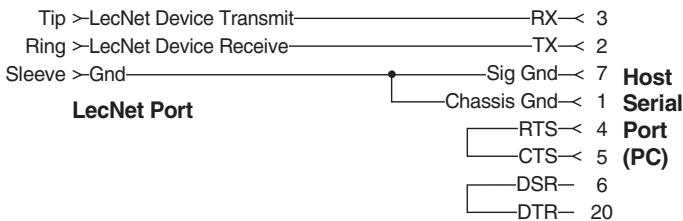

## LecNet Device to AMX or Crestron

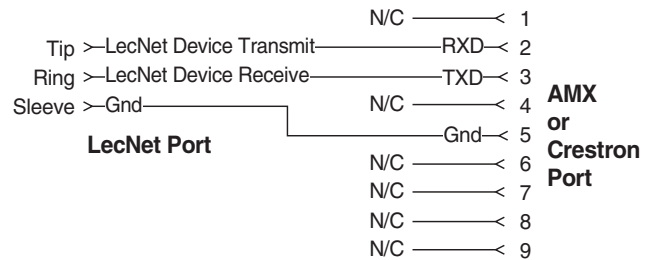
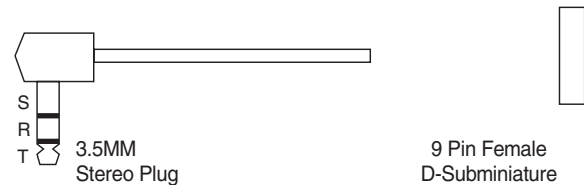

## AMX Programming Notes

If you are using an AMX system to control your LecNet equipment, you'll want to purchase the Lectrosonics PT3 Protocol Translator. The PT3 connects between the AMX bus and any LecNet equipment. With the PT3, the LecNet equipment looks just like native AMX equipment. The PT3 is the fastest and most productive way to control LecNet devices with an AMX system.

## SERIAL PORT SOFTWARE COMMANDS

All LecNet devices use a modification of the typical one-to-one connection between two RS-232 compatible devices. LecNet devices have both an RS-232 transmitter and receiver section. The transmitter section is “tri-stated”, or placed in a high impedance mode, until the particular device is addressed. To facilitate the simple parallel connection of multiple devices on a single RS-232 port, an addressing scheme is employed to route commands from the host to the proper LecNet device. When a device receives its address from the host computer, it temporarily turns on its RS-232 transmitter long enough to send whatever data is requested by the host. In this way, multiple devices may drive a single transmit signal back to the host, because only the addressed device will turn on its transmitter.

Valid address values are 128-254 (80 hex-FE hex). 255 (FF hex) is an invalid address and must not be used. Because a LecNet device will interpret any single data byte whose value is greater than 127 as an address, single byte data (as opposed to addresses) sent from the host must be in the range of 0-127. If a data value needs to be sent from the host that exceeds 127, the host must format two bytes of output such that the first byte is the lower 7 bits of the 8 bit value, and the second byte is 1 if the MSB of the data byte is 1, or 0 if the MSB of the data byte is 0.

All interchange of commands and data with any LecNet device should be done in hex rather than ASCII. The only exception to this is the return data on the Get Device Name command (see command description below).

Each LecNet command must be preceded by the address of the device to be controlled. If a device with the requested address exists on the system, it will respond by sending a 0 (0 hex, not ASCII) back to the host. Thus, each interchange with a LecNet device follows this pattern:

- 1) Host sends device address (133) in hex (1 byte);
- 2) Host receives byte of 0 hex from the LecNet device as acknowledgment;
- 3) Host sends command (1 byte, hex) to the LecNet device;
- 4) Host and LecNet device exchange data based on particular command sent.

Note that some LecNet commands cause LecNet devices to return an additional acknowledgment byte of data to confirm the end of a transaction. This is most typical of commands that cause the LecNet device to be busy for more than a few milliseconds processing the command. The additional acknowledgment byte lets the host know that the LecNet device is no longer busy and can receive more commands. If a command does return an additional acknowledgment byte, this will be explicitly stated in the command description.

As an example of a specific interchange between a host and an TH2 the following general procedure would be used to get a name string back from an TH2:

Set up the communications parameters of the device which will be the host. The correct parameters for all LecNet devices are 9600 baud, no parity, 8 data bits, 1 stop bit. This must only be done once when the host is initialized.

- 1) Host sends device address. For a factory default TH2, this would be 133, or 85 hex (1 byte);
- 2) Host receives byte of 0 hex from the TH2 as acknowledgment;
- 3) Host sends command 1 hex (1 byte) to the TH2 to get the name data;
- 4) The LecNet device sends to the host 4 bytes. The first byte is 3 hex, which is the number of bytes in the TH2's name string. The TH2 will then send the ASCII characters “T”, “H”, and “2” to the host.

The following section is a listing of available commands grouped based on the TH2 function to which the commands are related. The word “Host” in the command descriptions means the IBM PC or compatible, AMX controller, or Crestron controller to which the TH2 is connected. Note that Lectrosonics supplies AMX include files for controlling all LecNet devices. These files are included on the LecNet Master Pro setup disks which ship with each LecNet device. The files are automatically installed on your system during the LecNet installation. If you use the default setup subdirectory of “c:\lecnet”, the AMX include files will be found in “c:\lecnet\amx”.

There are several “status” flags that may be set by the host computer. Those flag commands that store the new value in EEPROM will continue to have the new value even if the power to the TH2 is turned off.

The following commands are described from the perspective of the host. A “Get” command allows the host to receive information from the TH2. A “Set” command allows the host to send information to set some parameter in the TH2.

## General Device Commands

**Get Device Name** - Causes the TH2 to send its "name" string back

**Host sends command** - dec 1 or hex 01

**Host receives data bytes:** byte 1 is the length of the name string (3 for TH2), bytes 2, 3, and 4 are the ASCII representation for the device name "TH2", i.e. dec (84, 74, 50). or hex (54, 4A, 32)

**Set Device Address** - Changes the TH2 device address and stores the new address in EEPROM.

Host sends command - dec 2 or hex 02

Host sends 1 byte representing device address of valid range 128 to 254.

**Get Firmware Version**

Host sends command - dec 25 or hex 19

Host receives 1 byte representing firmware version stored in MCU. For example, version 1.1 would be received as dec 11 or hex 0B.

## PC Local/Remote Mode Commands

**Set PC Local/Remote Mode** - forces change of mode by storing new mode in EEPROM

Host sends command - dec 11 or hex 0B

Host sends 1 byte which gets stored in EEPROM; 0 represents PC local mode, while 1 represents PC remote mode.

Host receives 1 byte representing the acknowledge byte.

**Get PC Local/Remote Mode**

Host sends command - dec 12 or hex 0C

Host receives 1 byte corresponding to the current TH2 mode; 0 represents PC local mode, while 1 represents PC remote mode.

**Get DSP Version**

**Host sends command** - dec 127 or hex 7F

**Host receives one byte** representing DSP version

**Re-initialize Digital Filter**

**Host sends command** - dec 126 or hex 7E

This will reconverge the digital filter coefficients without losing the telephone connection. This is very useful when a bridging service or DTMF cards change the impedance of the line.

## Dip Switch Commands

**Set Dip Switch Positions**

Host sends command - dec 13 or hex 0D

Host sends 1 byte which gets stored in EEPROM; byte representation is as follows:

BIT#	FUNCTION
0	Echo Suppression 1
1	Echo Suppression 2
2	Auto Answer
3	Auto Attenuation
4	Auto Initialize
5	Volume Limit 1
6	Volume Limit 2
7	Not Used

Host receives 1 byte representing the acknowledge byte.

**Get Dip Switch Positions**

Host sends command - dec 14 or hex 0E

Host receives 1 byte, whose representation is the same as in "Download Dipswitch Positions" above

## PC Remote Control Commands

### Set PC Remote Volume Up Flag

Host sends command - dec 15 or hex 0F

Host sends 1 byte representing the PC remote volume up status. This byte has a value of "1" when the Volume Up button is pressed.

### Set PC Remote Volume Down Flag

Host sends command - dec 16 or hex 10

Host sends 1 byte representing the PC remote volume down status. This byte has a value of "1" when the Volume Down button is pressed.

### Set PC Remote Privacy Flag

Host sends command - dec 17 or hex 11

Host sends 1 byte representing the privacy status. This byte has a value of "1" when the Privacy button is pressed.

### Set PC Remote Connect Flag

Host sends command - dec 20 or hex 14

Host sends 1 byte representing the connect status. This byte has a value of "1" when the Connect button is pressed.

### Get Connect Status

Host sends command - dec 22 or hex 16

Host reads 1 byte representing the connect status. This byte has a value of "1" when the TH2 is connected, and has a value of "0" when the TH2 is disconnected.

### Get Privacy Status

Host sends command - dec 23 or hex 17

Host receives 1 byte representing the privacy status. This byte has a value of "1" when Privacy is ON, and has a value of "0" when Privacy is OFF.

### Get Receive Gain Status

Host sends command - dec 21 or hex 15

Host receives 1 byte representing the current receive gain level (refer to the table below.)

Decimal Data	Hex Data	Gain	Decimal Data	Hex Data	Gain	Decimal Data	Hex Data	Gain
0	00	+6	7	07	-1	13	0D	-7
1	01	+5	8	08	-2	14	0E	-8
2	02	+4	9	09	-3	15	0F	-9
3	03	+3	10	0A	-4	16	10	-10
4	04	+2	11	0B	-5	17	11	-11
5	05	+1	12	0C	-6	18	12	-12
6	06	0				19	13	Off

## SPECIFICATIONS

<b>Connectors:</b>	
<b>Audio:</b>	8-pin mini DIN and depluggable terminal blocks
<b>Telephone/Line:</b>	RJ-11 Modular
<b>Wired Remote Control:</b>	DB-9
<b>Output Audio:</b>	Actively balanced
<b>Output Impedance:</b>	200 Ohms, balanced; 100 Ohms unbalanced
<b>Input Audio:</b>	Actively balanced, RF filtered
<b>Input Impedance:</b>	20k Ohms, balanced; 20k Ohms, unbalanced
<b>Telephone Hybrid:</b>	Standard hybrid transformer with DSP line return cancellation
<b>Auto Answer/Disconnect:</b>	Selectable - answers after first complete ring; Hangs up after loop reversal
<b>Volume Control:</b>	Local and Remote
<b>Range:</b>	+6dB to 12dB and Off in 1dB steps.
<b>Range Limit:</b>	Selectable - No limit; +6dB/-12dB; +6dB/-6dB;+3dB/-6dB
<b>Echo Suppression:</b>	Selectable: Auto, 12dB, 18dB, 24dB
<b>Call Frequency Response:</b>	±3dB 300Hz to 3.5kHz
<b>Caller THD (250Hz to 3.3kHz):</b>	Less than 0.2% (Receive Limit LED On)
<b>Send THD (250Hz to 3.3kHz):</b>	Less than 0.2% (Transmit Limit LED On)
<b>Maximum Output Level:</b>	+18dBu
<b>Serial Communication (RS-232):</b>	9600 baud, 8 data bits, no parity, 1 stop bit
<b>Power Requirements:</b>	280mA at 20VAC
<b>Power Consumption:</b>	10 Watts max at 20VAC
<b>Weight:</b>	3 lbs.
<b>Dimensions:</b>	19" wide, 1.75" high, 4.75" deep

*Specifications subject to change without notice.*

## ACCESSORIES

Part Number	Description
<b>Standard</b>	
21552	15 ft. Telephone cable with RJ-11 connectors
21553	9-pin male D-sub connector
21554	Shell for 9-pin D-sub connector
21551	12" mini DIN expansion cable
21529	9-pin D-sub to stereo mini plug serial cable
CH40	110V AC power supply
LNETWIN	3.5" floppy disk with LecNet software
M-TH2	TH2 instruction manual
35679	mini straight slot screwdriver
<b>Optional</b>	
RCW-TEL	Wall plate remote control unit.
RCW-DESK	Table top remote control unit



---

## SERVICE AND REPAIR

If your system malfunctions, you should attempt to correct or isolate the trouble before concluding that the equipment needs repair. Make sure you have followed the setup procedure and operating instructions. Check out the interconnecting cords and then go through the TROUBLE SHOOTING section in the manual

We strongly recommend that you **do not** try to repair the equipment yourself and **do not** have the local repair shop attempt anything other than the simplest repair. If the repair is more complicated than a broken wire or loose connection, send the unit to the factory for repair and service. Don't attempt to adjust any controls inside the units. Once set at the factory, the various controls and trimmers do not drift with age or vibration and never require readjustment. **There are no adjustments inside that will make a malfunctioning unit start working.**

LECTROSONICS service department is equipped and staffed to quickly repair your equipment. In-warranty repairs are made at no charge in accordance with the terms of the warranty. Out of warranty repairs are charged at a modest flat rate plus parts and shipping. Since it takes almost as much time and effort to determine what is wrong as it does to make the repair, there is a charge for an exact quotation. We will be happy to quote approximate charges by phone for out of warranty repairs.

## RETURNING UNITS FOR REPAIR

You will save yourself time and trouble if you will follow the steps below:

**A.** DO NOT return equipment to the factory for repair without first contacting us by letter or by phone. We need to know the nature of the problem, the model number and the serial number of the equipment. We also need a phone number where you can be reached 8 am to 4 pm (Mountain Standard Time).

**B.** After receiving your request, we will issue you a return authorization number (R.A.). This number will help speed your repair through our receiving and repair departments. The return authorization number must be clearly shown on the outside of the shipping container.

**C.** Pack the equipment carefully and ship to us, shipping costs prepaid. If necessary, we can provide you with the proper packing materials. UPS is usually the best way to ship the units. Heavy units should be "double-boxed" for safe transport.

**D.** We also strongly recommend that you insure the equipment, since we cannot be responsible for loss of or damage to equipment that you ship. Of course, we insure the equipment when we ship it back to you.

**Mailing address:**

Lectrosonics, Inc.  
PO Box 15900  
Rio Rancho, NM 87174  
USA

**Shipping address:**

Lectrosonics, Inc.  
581 Laser Rd.  
Rio Rancho, NM 87124  
USA

**Telephones:**

Regular: (505) 892-4501  
Toll Free (800) 821-1121  
FAX: (505) 892-6243

**World Wide Web:** <http://www.lectrosonics.com>

**Email:** [sales@lectrosonics.com](mailto:sales@lectrosonics.com)

## LIMITED ONE YEAR WARRANTY

The equipment is warranted for one year from date of purchase against defects in materials or workmanship provided it was purchased from an authorized dealer. This warranty does not cover equipment which has been abused or damaged by careless handling or shipping. This warranty does not apply to used or demonstrator equipment.

Should any defect develop, we will, at our option, repair or replace any defective parts without charge for either parts or labor. If we cannot correct the defect in your equipment, we will replace it at no charge with a similar new item. We will pay for the cost of returning your merchandise to you.

This warranty applies only to items returned to us, shipping costs prepaid, within one year from the date of purchase.

This warranty gives you specific legal rights. You may have additional legal rights which vary from state to state.

### **LECTROSONICS, INC.**

---

581 LASER ROAD  
RIO RANCHO, NM 87124 USA

May 10, 2000