

H187

VHF Narrowband Plug-On Transmitter



- **Crystal Controlled Fixed Frequency**
- **Wide Range Input Limiting**
- **Floating, Auto Latching Input Coupler**
- **Machined Aluminum Construction**

Fill in for your records:

Serial Number:

Purchase Date:

The H187 transmitter is FCC type accepted under Part 90 (150-172 MHz), and Part 74 (174-216 MHz)

Table of Contents

| | |
|-------------------------------------|----|
| Introduction | 5 |
| General Technical Description | 5 |
| H187 Block Diagram | 5 |
| Controls and Functions | 6 |
| Input Jack | 6 |
| Power/Mute Switch | 6 |
| Power On/Off LED | 6 |
| Modulation LEDs..... | 6 |
| Level LED | 6 |
| Limit LED | 6 |
| Mic Level | 6 |
| Operating Instructions..... | 7 |
| Battery Replacement | 8 |
| Specifications and Features..... | 8 |
| Troubleshooting..... | 9 |
| Symptom Possible Cause..... | 9 |
| Service and Repair | 10 |
| Returning Units for Repair | 10 |

Introduction

Thank you for selecting Lectrosonics wireless. This VHF transmitter is part of a family of narrowband wireless components that have served the needs of television broadcast and motion picture production markets since 1988.

The H187 plug-on transmitter replaces earlier versions, updating the design with surface mount PCB construction and the latest electronic components. The input coupler has evolved since the first versions were introduced, making it more rugged and better able to adapt to the wide variety of different XLR connectors found on

hand held and shotgun microphones.

The housing and external mechanical parts are constructed of machined aluminum to provide the ruggedness needed in field production. The battery door remains attached to the housing when opened, and the control panel is recessed to prevent damage from rough handling. These and other features have been added or modified since the first versions were introduced. The H187 remains a workhorse in broadcast ENG, continuing the Lectrosonics commitment to quality.

General Technical Description

The H187 transmitter is comprised of four major functional subsystems: the mic preamp/gain control, the compandor, the compressor/limiter and the RF transmitter (see block diagram below).

The mic preamp is an ultra-low noise type op-amp. Aside from gain control, this stage also adds high frequency pre-emphasis to the audio signal. This insures highest signal-to-noise ratios under varying signal conditions. Gain control is semi-logarithmic to provide smooth gain control action.

The compandor is a high quality audio device that processes the input signal such that large dynamic ranges of input signal can be transmitted to the receiver without overload or noise. A complementary system in the receiver recovers the original dynamics of the signal for full audio quality. Compression and expansion ratios are complementary at 2:1. High frequency pre-emphasis is implemented in the transmitter to provide another 10dB signal-to-noise ratio improvement. Matching de-emphasis is provided in all receivers.

The compressor/limiter is a low distortion shunt FET compressor. Control signals for the compressor are derived after the compandor to eliminate any possibility of overload under any signal condition up to a maximum of

3 Volts input. The range of limiting action before gross distortion occurs is 35dB.

The compandor in the 187 series transmitters is much tighter than the 185 series. The H187 compandor will hold the transmitter deviation to no more than $\pm 15\text{kHz}$ under all circumstances. The 185 compandor would allow some excursions beyond 15kHz during strong audio "spikes."

The RF transmitter is composed of the crystal stabilized main oscillator followed by a frequency tripler and two frequency doublers. All three stages are double tuned. Double tuning provides maximum attenuation of spurious signals, which in turn minimizes the possibility that a transmitter would interfere with another transmitter/receiver system on another frequency.

All RF stages are biased from a regulated internal source. The output stage has a separate feedback regulator which not only stabilizes its operating point, but also minimizes AM distortion. These regulators keep the RF performance consistent from the beginning (9 Volts) to the end (6.5 Volts) of battery life.

Schematics and alignment instructions will be provided to qualified repair personnel on request.

H187 Block Diagram

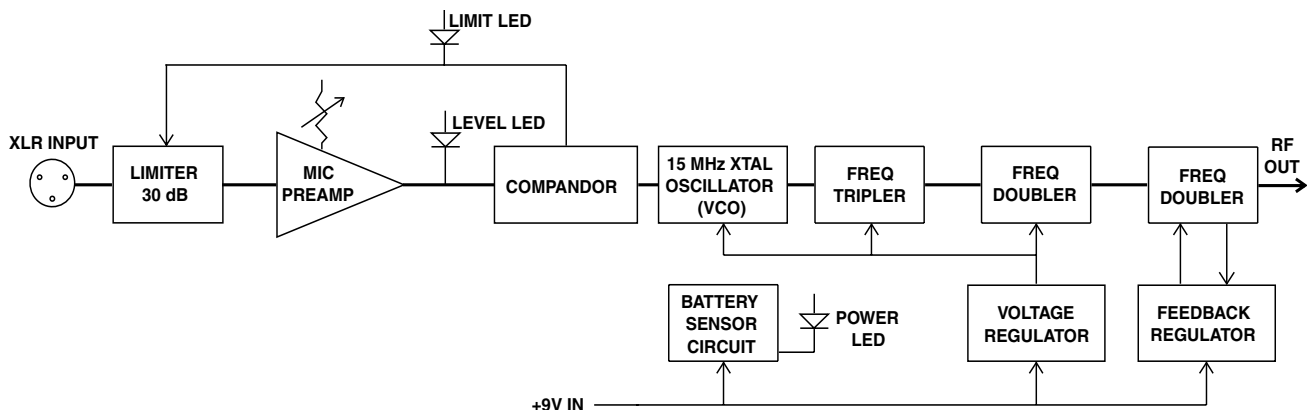

Controls and Functions

The H187 may be used with a wide variety of microphones. The 3-pin XLR type connector on the H187 allows the transmitter to be used with any dynamic microphone, as well as many two wire positive bias lavalier systems (such as those systems supplied by Lectrosonics.)

Input Jack

Standard 3-pin Switchcraft XLR type. Pin 2 is signal, pin 3 is signal ground, and pin 1 is case ground (see schematic below). The H187 is self-locking onto a standard microphone. The XLR connector is permanently bonded to the metal collar, and is not normally replaceable. The electret bias is 5 Volts at 1mA or less. The bias is connected in a “phantom” manner and will not interfere with any standard balanced microphone. If severe noise is experienced when the microphone is moved with respect to the H187, the cause is an unbalanced condition between pins 2 and 3 of the microphone.

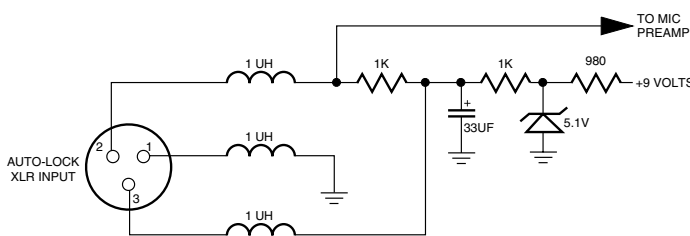

Input Jack Schematic

Power/Mute Switch

Turns the battery power on and off. The center position is an “audio mute” which should be used when setting the MIC LEVEL control. The “mute” position disconnects the audio signal from the transmitter and allows you to adjust the audio modulation level without the possibility of feedback. When turning the transmitter on, pause for a moment in the “mute” position. This will prevent a turn-on surge from occurring (a “thump” sound).

Power On/Off LED

Glow brightly when battery is good. A weak or dim LED means that the battery is weak, and has about an hour of operation left. If the LED fails to light, the battery should be replaced. The power LED should light up in both the “mute” and “on” positions of the POWER/MUTE SWITCH.

The POWER LED is connected to a precision battery test circuit that continuously monitors battery voltage. The LED is at full brightness with a new 9 Volt alkaline. As the battery voltage drops during use, the LED brightness will also decrease. After 12 to 15 hours the battery voltage will be about 7 Volts. The LED will be completely extinguished. Since the internal circuits are all tightly regulated and the RF output stage has a separate discrete regulator, the transmitter will continue

to operate to a battery voltage of 6.5 Volts. From 6.5 Volts to 6 Volts, the transmitter will still operate, but with degraded performance. Please note that a weak battery will sometimes light the POWER LED immediately after turn on, but soon will discharge to the point where the LED will extinguish.

The combination of an accurate battery condition indicator and regulation of all internal circuits guarantees much longer battery life, as well as consistent performance versus battery life.

Modulation LEDs

Indicate the proper setting of the MIC LEVEL control.

Level LED

Flickers or glows all the time if the audio volume is adequate for normal operation.

Limit LED

Lights up when the audio volume is high, indicating that the signal level is being limited by the compressor. Optimum signal-to-noise ratio is obtained when the limit LED lights occasionally.

Mic Level

Used to adjust the audio input volume for the proper modulation level. Rotate knob until the LEVEL LED flickers when there is an input signal. The LIMIT LED should light occasionally.

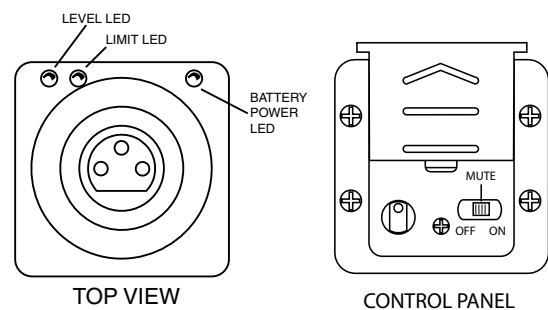

Operating Instructions

- 1) Insert the H187 into the selected microphone. Listen for the “click” that indicates the H187 has locked on to the microphone. Pull on the mic to insure proper locking has occurred.
- 2) Turn the power switch to the “MUTE” position on both the transmitter and the receiver. The “MUTE” position allows internal voltages to stabilize before audio signal paths are opened.
- 3) Hold the microphone as you will when you will be using it.
- 4) Speak as loudly as you expect to speak in normal system use. Rotate the MIC LEVEL knob so that the LEVEL LED flickers or stays lit as you speak. The LIMIT LED should light up on loud “peaks.” *Occasional lighting of the LIMIT LED (about 10-15% of the time) indicates proper operation and optimum signal-to-noise ratio.* Even when the transmitter is limiting, little distortion is produced because of the high linearity of the gain control circuit in the H187.
- 5) Move switches to “ON” position on both the transmitter and the receiver and adjust the volume of the sound system.

NOTE: The MIC LEVEL control should not be used to control the volume of your sound system. This is accomplished using the level control on the receiver, or a level control on the mixing console.

If the mic level is too high — the LIMIT LED will light frequently or stay on. This condition may cause distortion.

If the mic level is too low — neither LED will light, or the LEVEL LED will light dimly. This condition will cause hiss and noise. You may experience severe reduction in apparent range if the modulation level is too low. It may sound as if you are getting dropouts. What is actually happening is that you are hitting your noise floor because the S/N ratio has been compromised by the low modulation.

The LEVEL LED turns on at -10dB below full deviation. The LIMIT LED turns on at full deviation and indicates that the input shunt compressor is operating. The input compressor operates over a full 35dB range regardless of the gain control setting. The compressor uses a true absolute value circuit to detect both positive and negative peaks. The attack time is 2 milliseconds and the release time is 80 milliseconds. Occasional limiting is desirable, indicating that the gain is correctly set and the transmitter is fully modulated.

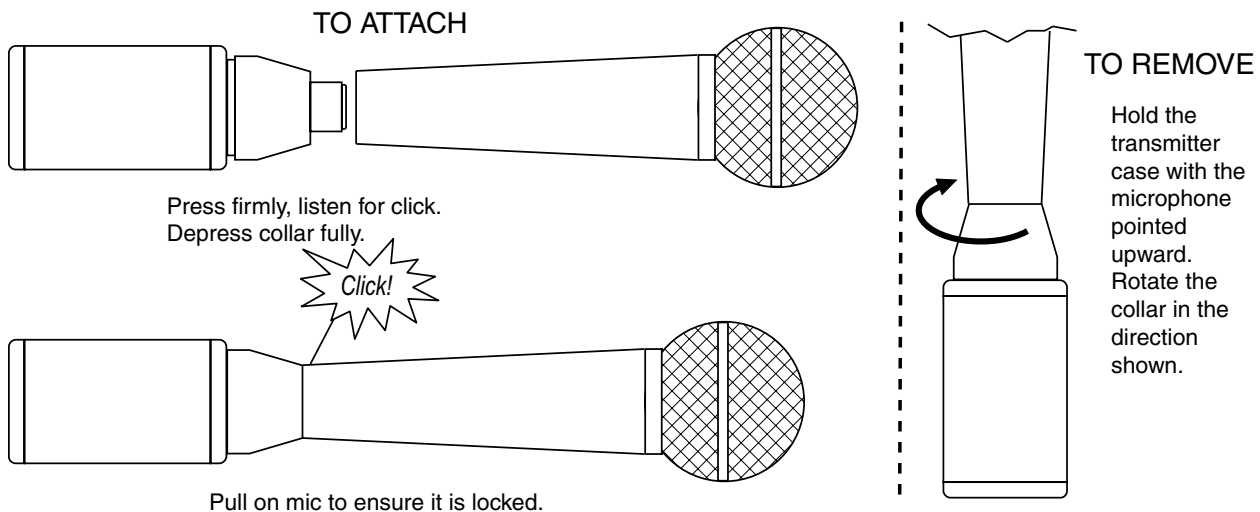

Battery Replacement

The H187 transmitter is powered by a standard alkaline 9 Volt battery. It is important that you use ONLY an ALKALINE battery for longest life. Standard zinc-carbon batteries marked "heavy duty" or "long-lasting" are not adequate. They will provide only about 4 hours of operation. Similarly, nicad rechargeable batteries only give 4 hours of operation, and will also run down quite abruptly. Alkaline batteries provide about 15 hours of operation.

To open the battery compartment, press outward on the cover door in the direction of the arrow as shown in the drawing. Only slight, sliding pressure is needed to open and close the battery door.

Swing the door open and take note of the polarity marked inside showing the location of the positive (+) and negative (-) terminals. Insert the battery and close the cover by pressing in and across, reversing the opening procedure outlined above. Note that the battery door will NOT close if the battery is inserted incorrectly, since the terminals will hit a protective polarity barrier.

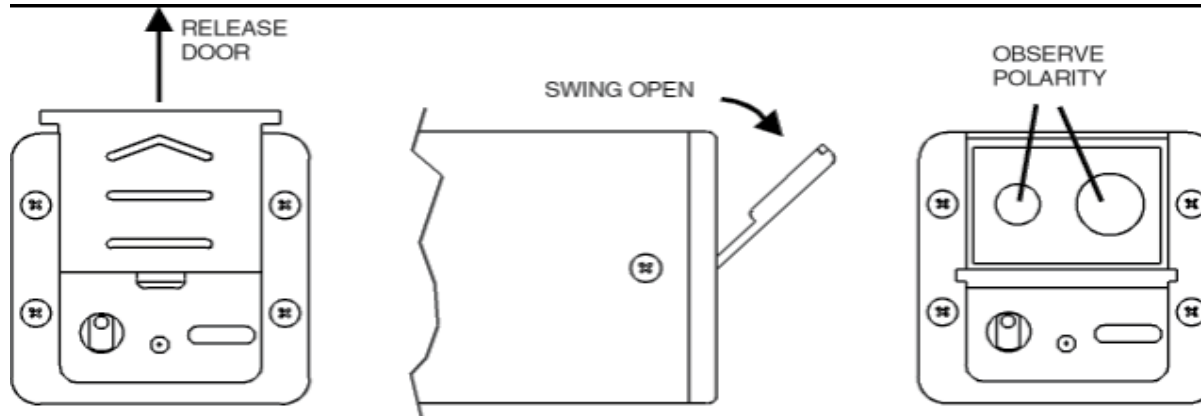

Specifications and Features

| | | | |
|--------------------------------|---|-------------------------------|--|
| Traveling frequencies: | 169.505 170.245 171.045 171.905 | Gain control range: | 43dB; semi-log rotary control |
| RF Power output: | 50mW | Modulation indicators: | Dual LEDs indicate modulation level and onset of limiting |
| Deviation: | ±15kHz | Controls: | 3 position "OFF-MUTE-ON" for noiseless operation; rotary knob adjusts audio gain |
| Spurious radiation: | 55dB below carrier | Connector: | 3-pin XLR type with auto-locking collar |
| Equivalent input noise: | -126dBV | Battery: | Any 9 Volt alkaline battery |
| Input level: | Nominal 2mV to 300mV (before compression) | Weight: | 7 ozs. including battery |
| Input impedance: | 22k Ohms (compatible with all Lo-Z microphones) | Dimensions: | 1.5 x 1.5 x 4.2 inches |
| Input compressor: | Soft compressor, 35 dB range allows 3 Volt max. input | Emission Designator: | 54KOF3E |

Specifications subject to change without notice.

Troubleshooting

Before going through the following chart, be sure that you have a good battery in the transmitter - the red power LED on the transmitter panel should glow brightly.

Symptom

Transmitter Battery LED Off

No Transmitter Modulation LEDs

No Sound is Heard and Receiver Lamp is Off

No Audio is Heard But Receiver RF LED Is On

No Sound and Receiver Mod Level LEDs Are Off

No Sound and Receiver Mod Level LEDs Are On

Noise (Hiss) is Heard Along With the Signal

Distorted Sound

Excessive Feedback

Possible Cause

- 1) Battery is inserted backwards.
- 2) Battery is dead.
- 1) Gain control turned all the way down.
- 2) Battery is in backwards. Check power LED.
- 3) Mic capsule is damaged or malfunctioning.
- 1) Transmitter not turned on.
- 2) Transmitter battery is dead.
- 3) Receiver antenna missing or improperly positioned.
- 4) Transmitter and receiver not on same frequency. Check labels on transmitter and receiver.
- 5) Operating range is too great.
- 1) On/Off switch is in "mute" position receiver or transmitter.
- 2) Microphone on/off switch is in "off" position.
- 3) Volume is turned down or off on transmitter or receiver.
- 4) Receiver not properly connected to other audio equipment.
- 5) Transmitter POWER switch may be turned on and off (i.e. through the mute position). A "thump" should be heard in the sound, again indicating a properly functioning receiver.

NOTE: If the modulation level LEDs on the receiver are indicating properly, the problem is NOT in the transmitter.

- 1) Transmitter audio muted. Make sure front panel power switch is in the on position.
- 1) Receiver audio is muted. Refer to receiver manual.
- 2) Receiver audio output is disconnected or cable is defective or mis-wired.
- 3) Sound system or recorder input is turned down.
- 1) MIC LEVEL is too low.
- 2) Transmitter and receiver may be too far from one another.
- 3) Receiver antenna may be defective or disconnected.
- 1) MIC LEVEL is too high.
- 2) Mic may be distorting; try a different mic and listen again.
- 3) PA system may be overloading.
- 1) Transmitter gain (audio level) too high. Check gain adjustment and/or reduce receiver output level.
- 2) Microphone too close to speaker system.
- 3) Microphone too far from user's mouth.
- 4) Sound system volume set too high.

Service and Repair

If your system malfunctions, you should attempt to correct or isolate the trouble before concluding that the equipment needs repair. Make sure you have followed the setup procedure and operating instructions. Check the interconnecting cables and then go through the **Troubleshooting** section in this manual.

We strongly recommend that you **do not** try to repair the equipment yourself and **do not** have the local repair shop attempt anything other than the simplest repair. If the repair is more complicated than a broken wire or loose connection, send the unit to the factory for repair and service. Don't attempt to adjust any controls inside the units. Once set at the factory, the various controls and trimmers do not drift with age or vibration and never require readjustment. **There are no adjustments inside that will make a malfunctioning unit start working.**

LECTROSONICS' Service Department is equipped and staffed to quickly repair your equipment. In warranty repairs are made at no charge in accordance with the terms of the warranty. Out-of-warranty repairs are charged at a modest flat rate plus parts and shipping. Since it takes almost as much time and effort to determine what is wrong as it does to make the repair, there is a charge for an exact quotation. We will be happy to quote approximate charges by phone for out-of-warranty repairs.

Returning Units for Repair

For timely service, please follow the steps below:

- A. DO NOT return equipment to the factory for repair without first contacting us by letter or by phone. We need to know the nature of the problem, the model number and the serial number of the equipment. We also need a phone number where you can be reached 8 A.M. to 4 P.M. (U.S. Mountain Standard Time).
- B. After receiving your request, we will issue you a return authorization number (R.A.). This number will help speed your repair through our receiving and repair departments. The return authorization number must be clearly shown on the **outside** of the shipping container.
- C. Pack the equipment carefully and ship to us, shipping costs prepaid. If necessary, we can provide you with the proper packing materials. UPS is usually the best way to ship the units. Heavy units should be "double-boxed" for safe transport.
- D. We also strongly recommend that you insure the equipment, since we cannot be responsible for loss of or damage to equipment that you ship. Of course, we insure the equipment when we ship it back to you.

Mailing address:

Lectrosonics, Inc.
PO Box 15900
Rio Rancho, NM 87174
USA

Shipping address:

Lectrosonics, Inc.
581 Laser Rd.
Rio Rancho, NM 87124
USA

Telephone:

(505) 892-4501
(800) 821-1121 Toll-free
(505) 892-6243 Fax

Web:

www.lectrosonics.com

E-mail:

sales@lectrosonics.com

Lectrosonics Canada:

Mailing Address:

720 Spadina Avenue,
Suite 600
Toronto, Ontario M5S 2T9

Telephone:

(416) 596-2202
(877) 753-2876 Toll-free
(877-7LECTRO)
(416) 596-6648 Fax

E-mail:

Sales: colinb@lectrosonics.com
Service: joeb@lectrosonics.com

LIMITED ONE YEAR WARRANTY

The equipment is warranted for one year from date of purchase against defects in materials or workmanship provided it was purchased from an authorized dealer. This warranty does not cover equipment which has been abused or damaged by careless handling or shipping. This warranty does not apply to used or demonstrator equipment.

Should any defect develop, Lectrosonics, Inc. will, at our option, repair or replace any defective parts without charge for either parts or labor. If Lectrosonics, Inc. cannot correct the defect in your equipment, it will be replaced at no charge with a similar new item. Lectrosonics, Inc. will pay for the cost of returning your equipment to you.

This warranty applies only to items returned to Lectrosonics, Inc. or an authorized dealer, shipping costs prepaid, within one year from the date of purchase.

This Limited Warranty is governed by the laws of the State of New Mexico. It states the entire liability of Lectrosonics Inc. and the entire remedy of the purchaser for any breach of warranty as outlined above. NEITHER LECTROSONICS, INC. NOR ANYONE INVOLVED IN THE PRODUCTION OR DELIVERY OF THE EQUIPMENT SHALL BE LIABLE FOR ANY INDIRECT, SPECIAL, PUNITIVE, CONSEQUENTIAL, OR INCIDENTAL DAMAGES ARISING OUT OF THE USE OR INABILITY TO USE THIS EQUIPMENT EVEN IF LECTROSONICS, INC. HAS BEEN ADVISED OF THE POSSIBILITY OF SUCH DAMAGES. IN NO EVENT SHALL THE LIABILITY OF LECTROSONICS, INC. EXCEED THE PURCHASE PRICE OF ANY DEFECTIVE EQUIPMENT.

This warranty gives you specific legal rights. You may have additional legal rights which vary from state to state.

