

# PDR

## Portable Digital Audio Recorder



### Quick Start Steps

- 1) Install good battery and turn the power on (p. 3, 6).
- 2) Insert microSDHC memory card and format it with the PDR (p. 3, 4).
- 3) Timecode jam source (p. 7, 8).
- 4) Connect microphone or audio source.
- 5) Set input gain (Mic Level p. 8).
- 6) Select record mode (p. 9).
- 7) Set output level (HP Volume p. 8).
- 8) Begin recording (p. 5-9).



microSDHC Logo is a trademark of SD-3C, LLC

***CAUTION: See card formatting warning on page 4.***

Follow Us On:



Fill in for your records:

Serial Number:

Purchase Date:

# Table of Contents

Quick Start Steps .....	1
<b>Introduction</b> .....	<b>2</b>
Broadcast Wave Format.....	2
Versatility and Compatibility .....	3
<b>Battery Installation</b> .....	<b>3</b>
<b>Compatible Memory Cards</b> .....	<b>3</b>
<b>Installing the Card</b> .....	<b>3</b>
<b>Formatting the SD Card</b> .....	<b>4</b>
<b>IMPORTANT</b> .....	<b>4</b>
META DATA .....	4
<b>Features and Controls</b> .....	<b>5</b>
Belt Clip.....	6
<b>Operating Instructions</b> .....	<b>6</b>
Powering On .....	6
Powering Off .....	6
Main Window.....	6
Recording Window .....	6
Playback Window .....	6
Navigating Menus.....	7
Timecode... ..	8
Mic Level .....	8
HP Volume .....	8
Scene & Take .....	8
SD Card.....	8
Settings.....	9
About PDR.....	9
Default.....	9
<b>Firmware Updates</b> .....	<b>9</b>
<b>Recovery Process</b> .....	<b>10</b>
<b>PDRRemote</b> .....	<b>11</b>
<b>5-Pin Input Jack Wiring</b> .....	<b>12</b>
<b>Microphone Cable Termination</b> for Non-Lectrosonics Microphones.....	<b>13</b>
<b>Wiring Hookups for Different Sources</b> .....	<b>14</b>
<b>Optional Accessories</b> .....	<b>15</b>
<b>Specifications</b> .....	<b>16</b>
<b>Available Recording Time</b> .....	<b>16</b>
<b>Service and Repair</b> .....	<b>17</b>
Returning Units for Repair .....	17

## Introduction

Congratulations on your purchase of the PDR (Personal Digital Recorder). On occasion, there is a need to record audio in circumstances where a traditional full sized recorder is impractical. Whether it be an extreme sport, a public speaking event, a wedding or a next-to-impossible location sound recording, the PDR is designed for the difficult audio capture. When talent is at an extreme distance or using a wireless microphone is not practical (knights in armor come to mind), the PDR can travel with your subject and record professional quality audio, synchronized with timecode. The recorder is unobtrusive and easily hidden in garments and costumes and easy to conceal when used as a “plant” microphone to capture environmental or location sound.

## Broadcast Wave Format

With a timecode jam at the start of the production, the audio data file contents include a timing reference to make it easy to synchronize them in the timeline. The industry standard BWF/.WAV file format is compatible with essentially any audio or video editing software.

## Versatility and Compatibility

The PDR can be tethered to a camera to capture a higher quality or backup audio recording. The headphone output doubles as a line output to feed the AV input on a camera.

The input connector is the industry standard TA5M jack that accepts any mic or line level signal, and provides bias voltage to power a wide variety of electret lavaliere microphones. The input connection and wiring is compatible with microphones pre-wired for “compatible” and “servo bias” configurations to feed 5-pin inputs on Lectrosonics wireless microphone transmitters.

Setup and adjustment is made through an intuitive interface provided by the keypad and LCD. In keeping with typical Lectrosonics mechanical designs, the housing is machined from a solid aluminum billet for the ruggedness needed in field production.

## Battery Installation

The audio recorder is powered by a single AAA Lithium battery for 6 hours of operation.

Zinc-carbon batteries marked “heavy-duty” or “long-lasting” are not adequate.

**NOTE:** Although alkaline batteries will work in the PDR, we strongly recommend that they be used only for short-term testing. For any actual production use, we recommend the use of disposable lithium AAA batteries.

Push inward on the release tabs to open the door.



Insert the battery according to the markings inside the battery compartment door. The (+) pos. end of the battery is oriented as shown here.



## Compatible Memory Cards

We have tested a wide variety of cards and these performed the best with no issues or errors.

- Lexar 16GB High Performance UHS-I (Lexar part number LSDMI16GBBNL300).
- SanDisk 16GB Extreme PLUS UHS-I (SanDisk part number SDSDQX-016G-GN6MA)
- Sony 16GB UHS-I (Sony part number SR16UXA/TQ)
- PNY Technologies 16GB Elite UHS-1 (PNY part number P-SDU16U185EL-GE)
- Samsung 16GB PRO UHS-1 (Samsung part number MB-MG16EA/AM)

## Installing the Card

The card slot is covered by a flexible cap. Open the cap by pulling out on the side flush with the housing.



Pull up on this side of cap to open

**CAUTION:**  
 Danger of explosion if battery is  
 incorrectly replaced.  
 Replace only with the same or equivalent type.

Insert the card with the label facing the keypad side of the recorder.



## Formatting the SD Card

SDHC cards come pre-formatted with a FAT32 file system which is optimized for good performance. The PDR relies on this performance and will never disturb the underlying low level formatting of the SD card. When the PDR “formats” a card, it performs a function similar to the Windows “Quick Format” which deletes all files and prepares the card for recording. The card can be read by any standard computer but if any write, edit or deletions are made to the card by the computer, the card must be re-formatted with the PDR to prepare it again for recording. The PDR never low level formats a card and we strongly advise against doing so with the computer.

To format the card with the PDR, select Format Card in the menu and press MENU/SEL on the keypad.

See pages 8-10 for details on navigating the menus.

**NOTE:** An error message will appear if samples are lost due to a poor performing “slow” card.

**WARNING: DO NOT PERFORM A LOW LEVEL FORMAT (COMPLETE FORMAT) WITH A COMPUTER. DOING SO WILL RENDER THE MEMORY CARD UNUSABLE WITH THE PDR RECORDER.**

**WITH A WINDOWS BASED COMPUTER, BE SURE TO CHECK THE QUICK FORMAT BOX BEFORE FORMATTING THE CARD.**

**WITH A MAC, BE SURE TO FORMAT AS “MASTER BOOT RECORD” AS SETTING.**

## IMPORTANT

The formatting of the PDR SD card sets up contiguous sectors for maximum efficiency in the recording process. The file format utilizes the BEXT (Broadcast Extension) wave format which has sufficient data space in the header for the file information and the time code imprint.

The SD card, as formatted by the PDR, can be corrupted by any attempt to directly edit, change, format or view the files on a computer.

The simplest way to prevent data corruption is to copy the .wav files from the card to a computer or other Windows or OS formatted media ***FIRST. Repeat – COPY THE FILES FIRST!***

**Do not** rename files directly on the SD card.

**Do not** attempt to edit the files directly on the SD card.

**Do not** save **ANYTHING** to the SD card with a computer (such as the take log, note files etc) - it is formatted for PDR use only.

**Do not** open the files on the SD card with any third party program such as Wave Agent or Audacity and permit a save. In Wave Agent, do not IMPORT - you can OPEN and play it but do not save or Import - Wave Agent will corrupt the file.

In short - there should be NO manipulation of the data on the card or addition of data to the card with anything other than a PDR. Copy the files to a computer, thumb drive, hard drive etc that has been formatted as a regular OS device FIRST - then you can edit freely.

## iXML HEADER SUPPORT

Recordings contain industry standard iXML chunks in the file headers, with the most commonly used fields filled in.

# Features and Controls

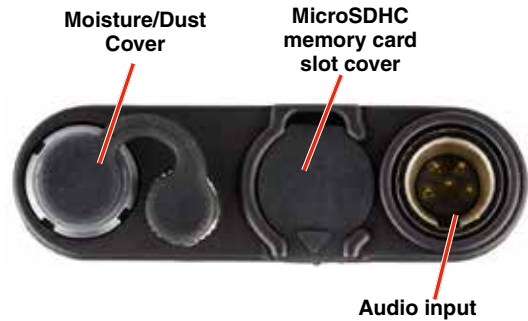
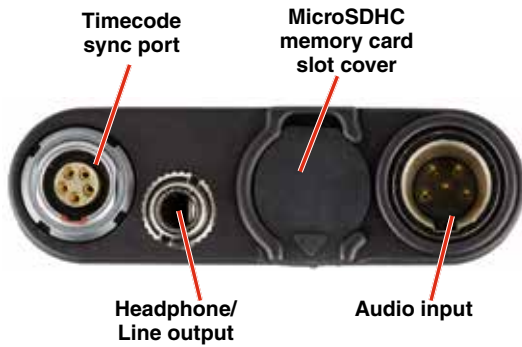

The audio input circuitry is the essentially the same as on Lectrosonics SM and L Series transmitters. Any microphone wired as Lectrosonics “compatible” or “servo bias” will work with the PDR. See page 10 for details.

If the unit is powered on with a card which hasn’t been formatted for the PDR, a prompt to format the card will appear. Follow the on-screen instructions to format the card. If the card has an interrupted recording on it, the Recovery screen will appear.

If there is no card in the PDR or the card is not properly formatted, the Main Window appears. Settings are accessed by pressing MENU/SEL on the keypad, and then using the UP and DOWN arrow buttons and **BACK** button to navigate the menu items and select functions. The buttons also provide alternate functions as labeled by the icons on the LCD.

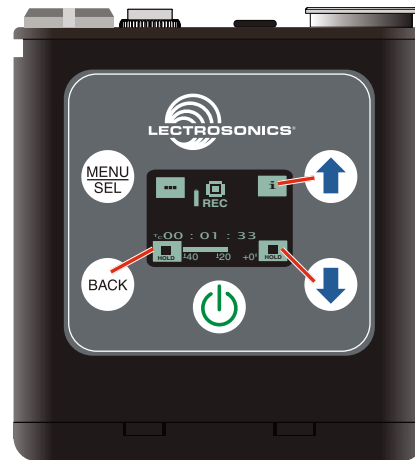

In the Playback Windows, the icons on the LCD change to provide the functions needed during playback. There are three variants of the playback window:

- active playback
- paused playback in the middle of the recording
- paused playback at the end of the recording

The icons in the corners of the LCD will change depending on the status of the playback.

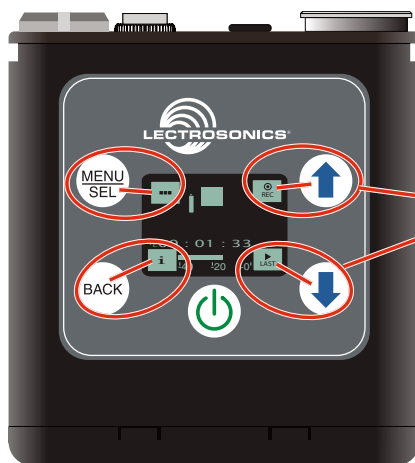

Functions indicated by the icons on the LCD are activated by pressing the adjacent buttons on the keypad

Icons in each corner of the LCD define the alternate functions of the adjacent buttons on the keypad. For example, in the Main Window shown above, recording is started by pressing the UP arrow button on the keypad, in which case, the display switches to the Recording Window.

In the Recording Window, the functions of three keypad buttons change to provide the needed operations during recording.



**NOTE:** Refer to the Operating Instructions section for details on the specific button functions and operations in the Main, Recording and Playback Windows.

## Belt Clip

PDR wire beltclip included.



The Main Window will alert you if there is no memory card in the PDR.

Question mark blinks

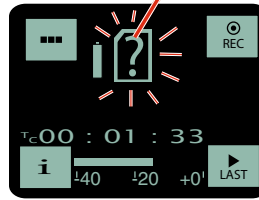

## Recording Window

To start recording, press the **REC** button in the top right corner of the Main Window. The screen will switch to the Recording Window.

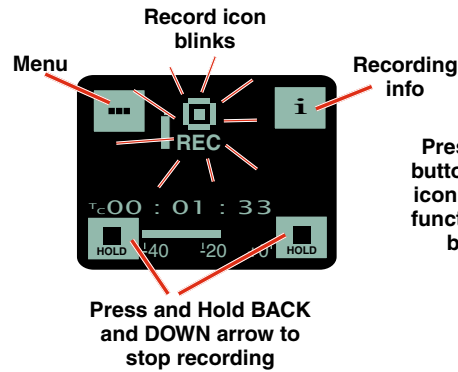

Press the keypad button next to each icon to operate the functions indicated by the icons

# Operating Instructions

## Powering On

Press and hold the Power Button until the Lectrosonics logo appears on the LCD.

## Powering Off

Power can be turned off by holding the Power Button in and waiting for the countdown. The Power Button will not work while the unit is recording (stop recording first before powering down) or if the front panel has been locked out by the operator (unlock the front panel first).

If the power button is released before the countdown reaches 3, the unit will remain turned on and the LCD will return to the same screen or menu that was displayed previously.

## Main Window

The Main Window provides a view of the battery status, timecode and the input audio level. Icons in the four corners of the screen provide access to the Menu, Info (available recording time if SD card installed, PDR info if no card in unit), and the **REC** (record start) and **LAST** (play last clip) functions. These functions are invoked by pressing the adjacent keypad button as shown on the previous page.

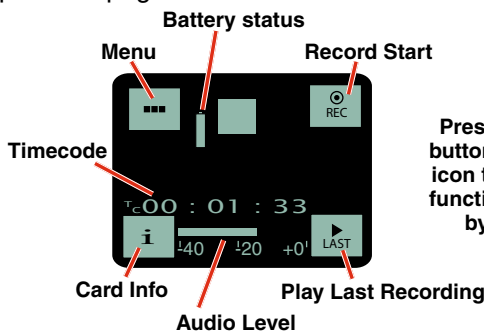

## Playback Window

Icons in the Playback Window provide button functions used for playback on a recording device. The icons will change depending on the status of the playback: active playback, paused in the middle, or paused at the end.

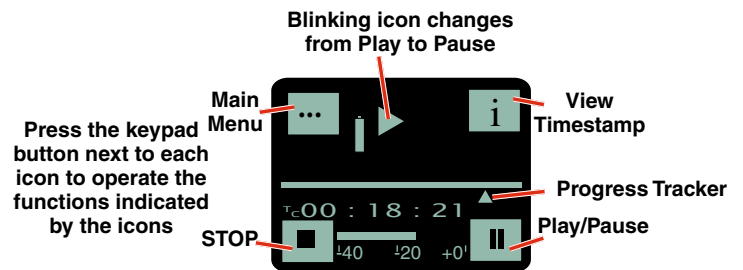

All files created are given a time stamp. See **File Naming** for options.



# Navigating Menus

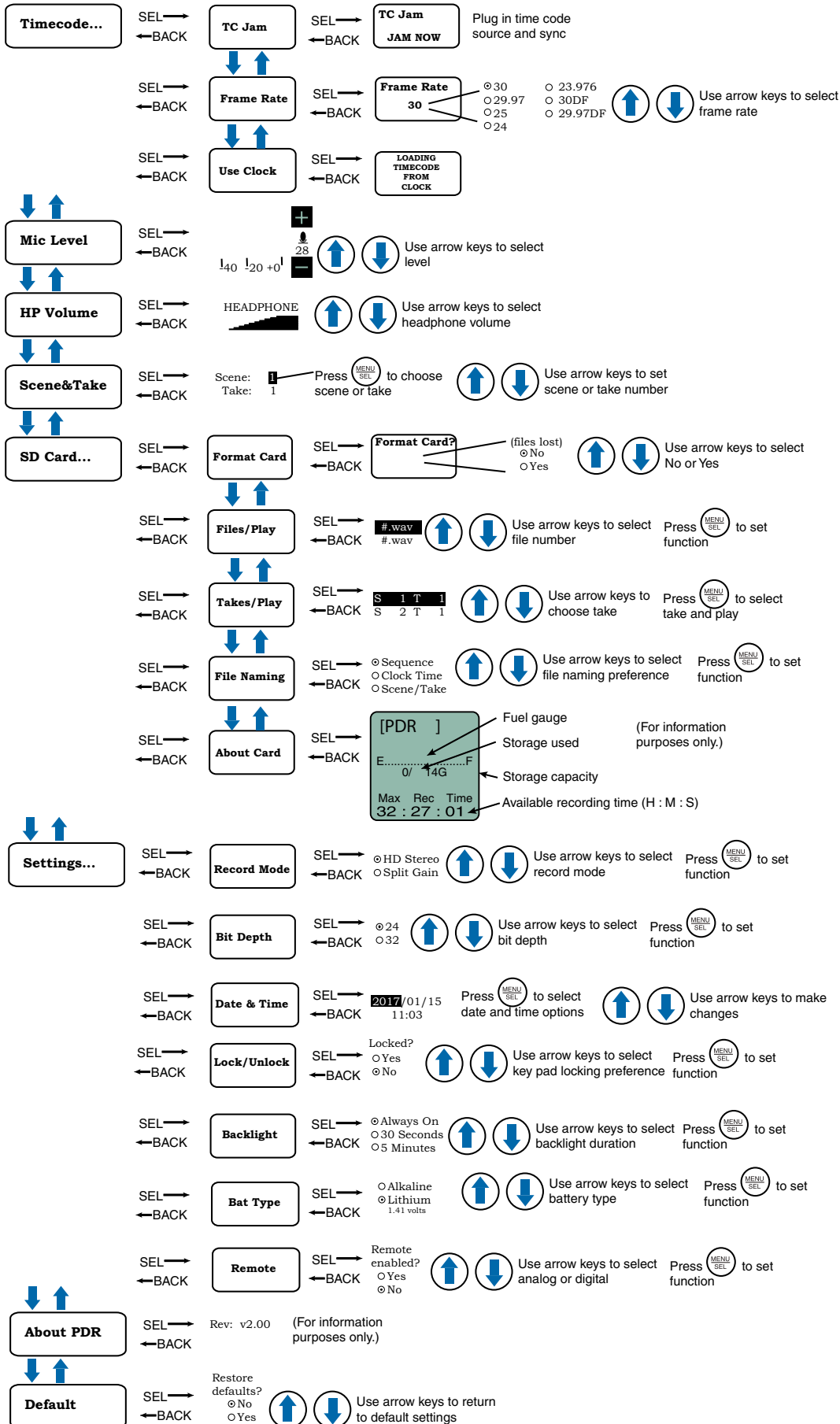

## Timecode...

### TC Jam (jam timecode)

When TC Jam is selected, **JAM NOW** will flash on the LCD and the unit is ready to be synced with the timecode source. Connect the timecode source and the sync will take place automatically. When the sync is successful, a message will be displayed to confirm the operation.

**WARNING: Timecode uses the main audio path. Take your headphones off when jamming timecode. DO NOT leave timecode cable in place during recording.**

Timecode defaults to zero at power up if no timecode source is used to jam the unit. A timing reference is logged into the BWF metadata.

### Frame Rate

The frame rate affects embedding of the timing reference in the BWF file metadata and display of timecode. The following options are available:

- 30
- 29.97
- 25
- 24
- 23.976
- 30DF
- 29.97DF

**NOTE:** While it is possible to change the frame rate, the most common use will be to check the frame rate which was received during the most recent timecode jam. In rare situations, it might be useful to alter the frame rate here, but be aware that audio tracks may not line up correctly with mismatched frame rates.

### Use Clock

Choose to use the clock provided in the PDR as opposed to a timecode source. Set the clock in the Settings Menu, Date & Time on page 9.

**NOTE:** The PDR time clock and calendar (RTCC) cannot be relied on as an accurate time code source. Use Clock should only be used in projects where there is no need for the time to agree with an external time code source.

### Mic Level

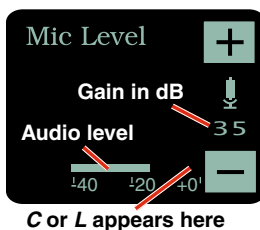

Use the UP and DOWN arrow buttons to adjust the input gain. When the audio level meter reading exceeds the zero at the top, either a “C” or an “L” icon will appear, indicating respectively clipping in the non-safety track (Split Gain mode) or limiting (HD Mono mode). In HD

Mono mode, the limiter compresses 30 dB of input level into the top 5 dB, reserved for “overhead” in this mode. In Split Gain mode, the limiter would rarely be engaged, but it will engage if necessary (with no graphical indication) to prevent clipping of the safety track.

**NOTE:** See Record Mode.

## HP Volume

Use UP and DOWN arrows to adjust headphone volume.

## Scene & Take

Each time recording is started, the PDR automatically begins a new take. Takes can run up to 999. The scene numbers can be manually entered and are limited to 99.

## SD Card...

### Format Card

This item erases all files on the card and prepares the card for recording.

### Files/Play

Choose to play the files based on their name. Use the arrows to scroll, MENU/SEL to select the file and the DOWN arrow to play.

### Takes/Play

Choose to play the files based on scene and take. Scene and take numbers can be manually entered, and are embedded in the filenames and iXML headers of recordings. Take number automatically increments each time the record button is pressed. When browsing by scene and take, recordings that span multiple files are listed singly and played as one long recording.

## File Naming

Filenames of the recordings contain industry standard iXML chunks in the file headers, with the most commonly used fields filled in. File naming can be set as:

- **Sequence:** a progressive sequence of numbers
- **Clock Time:** the time of the internal clock at the beginning of the recording; recorded as DDHHM-MA.WAV. DD is the day of the month, HH is hours, MM is minutes, A is the overwrite-prevention character, incrementing to ‘B’, ‘C’, etc. as needed to avoid a naming conflict. A final character serves as the segment identifier, being absent in the first segment, ‘2’ in the second segment, ‘3’ in the third and so on.
- **Scene/Take:** the progressive scene and take automatically cataloged each time a recording is begun; S01T001.WAV. The initial ‘S’ is meant to suggest “Scene” but also serves as the overwrite prevention character, decrementing to ‘R’, ‘Q’, etc. as needed to avoid a naming conflict. The “01” after the ‘S’ is the scene number. ‘T’ means take, and the “001” is the take number. An eighth character is used only for the second and subsequent (4 GB) segments for very large recordings. Scene numbers are entered manually. Take numbers increment automatically.



## About Card

View information about the microSDHC memory card. See storage used, storage capacity and available recording time.

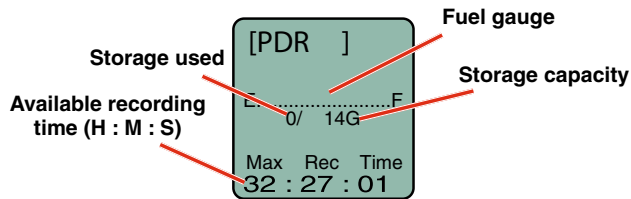

## Settings...

### Record Mode

There are two recording modes available in the menu, HD Mono, which records a single audio track and Split Gain, which records two different tracks, one at the normal level and another at -18 dB as a “safety” track that can be used in place of the normal track in the event that overload distortion (clipping) has occurred on the normal track. In either mode, recordings over 4GB are broken into sequential segments so very long recordings (over approx 5 hours in HD mode or 2.5 hours in split mode) will not be a single file.

**NOTE:** See Mic Level.

### Bit Depth

PDR defaults to 24-bit format recording, which is a more efficient space saving format. 32-bit is available if your editing software is older and won't accept 24-bit. (32-bit is actually 24-bit padded with zeros, so more space is taken up on the card.)

### Date & Time

The PDR has a real time clock/calendar (RTCC) which is used for timestamping the files it writes to the SD card. The RTCC is able to keep time for a minimum of 90 minutes with no battery installed, and can keep time more or less indefinitely if any battery, even a “dead” battery, is installed. To set the date and time, use the MENU/SEL button to toggle through the options and the UP and DOWN arrow buttons to choose the appropriate number.

**WARNING:** Since the real time clock/calendar can be manipulated and/or stop with loss of power, it should not be relied upon for accurate time keeping. Only use this option when a time clock is not available.

### Lock/Unlock

The LOCKED mode protects the recorder from accidental changes to its settings. When locked, menu navigation is possible, but any attempt to alter settings will prompt a “LOCKED/can use menu to unlock” message. The unit can be unlocked using the Lock/Unlock setup screen. The “dweedle tone” remote control will still work.

## Backlight

The recorder backlight can be set to turn off after either 5 minutes or 30 seconds, or to stay on continuously.

## Bat Type

Choose either Alkaline or Lithium battery type. The voltage of the installed battery will be shown at the bottom of the display.

**NOTE:** Although alkaline batteries will work in the PDR, we strongly recommend that they be used only for short-term testing. For any actual production use, we recommend the use of disposable lithium AAA batteries.

## Remote

The recorder can be configured to respond to “dweedle tone” signals from the PDRRemote app or to ignore them. Use the arrow buttons to toggle between “yes” (remote control on) and “no” (remote control off). The default setting is “no.”

## About PDR

The PDR's firmware version and serial number are displayed.

## Default

To return the recorder to its factory default settings, use the UP and DOWN arrow buttons to choose **Yes**.

## Firmware Updates

Firmware updates are made using a microSDHC memory card. Download and copy the following firmware update files to a drive on your computer.

- **pdr vX\_xx.ldr** is the firmware update file, where “X\_xx” is the revision number.

### In the computer:

- 1) Perform a Quick Format of the card. On a Windows-based system, this will automatically format the card to the FAT32 format, which is the Windows standard. On a Mac, you may be given several options. If the card is already formatted in Windows (FAT32) - it will be greyed out - then you do not need to do anything. If the card is in another format, choose Windows (FAT32) and then click “Erase.” When the quick format on the computer is complete, close the dialogue box and open the file browser.
- 2) Copy the **pdr v1\_xx.ldr** file to the memory card, then safely eject the card from the computer.

### In the PDR:

- 1) Leave the PDR turned off and insert the microSDHC memory card into the slot.

continued on next page...

- 2) Hold down both the UP and DOWN arrow buttons on the recorder and turn the power on.
- 3) The recorder will boot up into the firmware update mode with the following options on the LCD:
  - **Run** - Exits the update mode and starts up the recorder in the normal operating mode.
  - **Update** - Displays a scrollable list of the .ldr files on the card.
  - **Power Off** - Exits the update mode and turns the power off.

**NOTE:** If the unit powers on normally instead of offering the options in Step 3 (above), power the unit off and try again, making sure that both arrow buttons are firmly depressed while powering the unit back on.

- 4) Select **Update**. Use the UP and DOWN arrow buttons to select the desired file and press MENU/SEL to begin the update process. The LCD will display status messages while the firmware is being updated.

**NOTE:** The Update process takes about 20 seconds.

- 5) When the update is complete, the LCD will display this message: **UPDATE SUCCESSFUL REMOVE CARD**. After the card is removed, the LCD will return to the three options shown in step 3 above.
- 6) Select **Power Off** and press MENU/SEL to finish the update.
- 7) If you re-insert the same card and turn the power back on for normal use, the LCD will display a message prompting you to format the card:

**Format Card?  
(files lost)**

- **No**
- **Yes**

If you wish to record audio on the card, you must re-format it. Select **Yes** and press MENU/SEL to format the card. When the process is complete, the LCD will return to the Main Window and be ready for normal operation.

If you choose to keep the card as is, you may remove the card at this time.

The firmware update process is managed by a boot-loader program - on very rare occasions, you might need to update the bootloader.

- **pdrboot vX\_xx.ldr** is the bootloader file

Follow the same process as with a firmware update and select the pdrboot file. Be forewarned, this can corrupt your unit if interrupted. Don't update the bootloader unless advised to do so by the factory.

## Recovery Process

Recordings can be reliably recovered even if the card is accidentally removed or the battery dies while a recording is in progress. If a recording is interrupted, all of the audio is present on the card and can be easily recovered by the PDR. The PDR keeps track of the length of the most recent recording so it can supply a good suggestion for the length to recover. If the length is ever unknown or the PDR's suggestion seems incorrect, it is always possible to override the suggested length. If in doubt, specify the maximum length possible, in which case the entire remainder of the card is recovered. All of the interrupted recording will be present, followed by extra contents which might be random noise or audio from previously deleted recordings.

**NOTE:** A good battery is required to begin the recovery process. If recovery is attempted with a weak battery, a message appears saying that a fresh battery will be required.

Once a fresh battery has been installed, power on the PDR and insert the card with the interrupted recording. The PDR will detect the interrupted recording and display.

**INTERRUPTED  
RECORDING  
FOUND**

And then

**Recover?  
For safe use  
See manual**

If "No" is chosen, nothing is done to the card and the PDR will not use the card. If "Yes" is chosen, a prompt appears asking for the length of the recording to recover, specified as a number of hours and minutes. The default suggestion will be the approximate length of the most recent recording. It is always safe to recover a longer recording than was made. To specify the recovery time, use the MENU/SEL button to navigate and specify the hours and minutes fields. Once set as desired, use MENU/SEL to navigate to the "GO!" soft button and press the DOWN arrow button to begin the recovery process.

Recovery is nearly instantaneous. When completed, the display will show

**Recovery  
Successful**

# PDRRemote

By New Endian LLC

Convenient remote control is provided by a phone app available on the AppStore and Google Play. The app uses audio tones (“dweedle tones”) played through the phone’s speaker that are interpreted by the recorder to make changes to the recorder settings:

- Record Start/Stop
- Mic Gain Level
- Lock/Unlock

The PDR tones are unique to the PDR and will not react to “dweedle tones” meant for Lectrosonics transmitters.

The screens appear differently for iOS and Android phones, but perform the same functions.

## For Best Results

The following conditions are required:

- The microphone must be within range.
- The recorder must be configured to enable remote control activation. See **Remote** on the menu.

*Please be aware this app is not a Lectrosonics product. It is privately owned and operated by New Endian LLC, [www.newendian.com](http://www.newendian.com).*

## Android Version

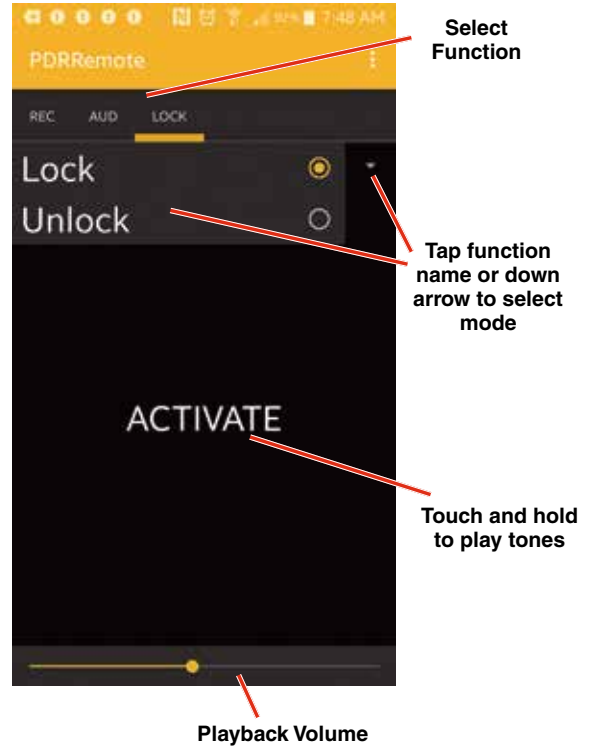

## iOS Version

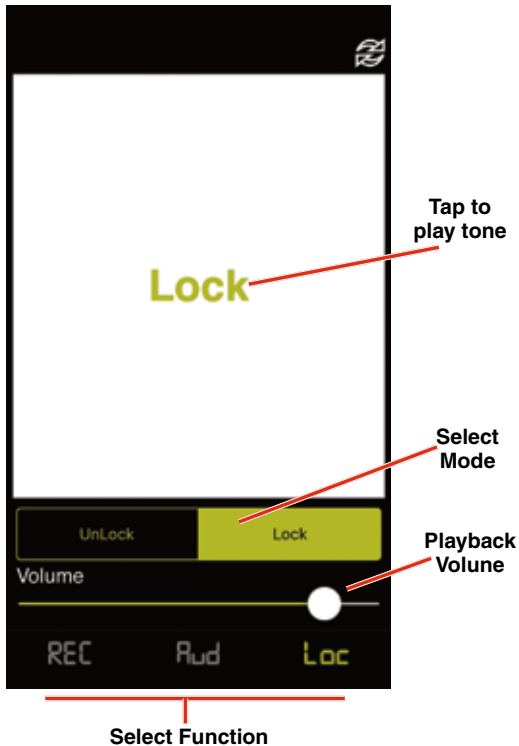

## 5-Pin Input Jack Wiring

The wiring diagrams included in this section represent the basic wiring necessary for the most common types of microphones and other audio inputs. Some microphones may require extra jumpers or a slight variation on the diagrams shown.

It is virtually impossible to keep completely up to date on changes that other manufacturers make to their products, thus you may encounter a microphone that differs from these instructions. If this occurs please call our toll-free number listed under Service and Repair in this manual or visit: [www.lectrosonics.com/US](http://www.lectrosonics.com/US)

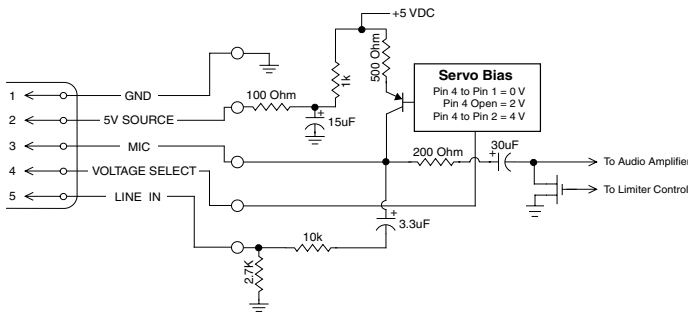

### Audio input jack wiring:

#### PIN 1

Shield (ground) for positive biased electret lavaliere microphones. Shield (ground) for dynamic microphones and line level inputs.

#### PIN 2

Bias voltage source for positive biased electret lavaliere microphones that are not using servo bias circuitry and voltage source for 4 volt servo bias wiring.

#### PIN 3

Microphone level input and bias supply.

#### PIN 4

Bias voltage selector for Pin 3.

Pin 3 voltage depends on Pin 4 connection.

Pin 4 tied to Pin 1: 0 V

Pin 4 Open: 2 V

Pin 4 to Pin 2: 4 V

#### PIN 5

Line level input for tape decks, mixer outputs, musical instruments, etc.

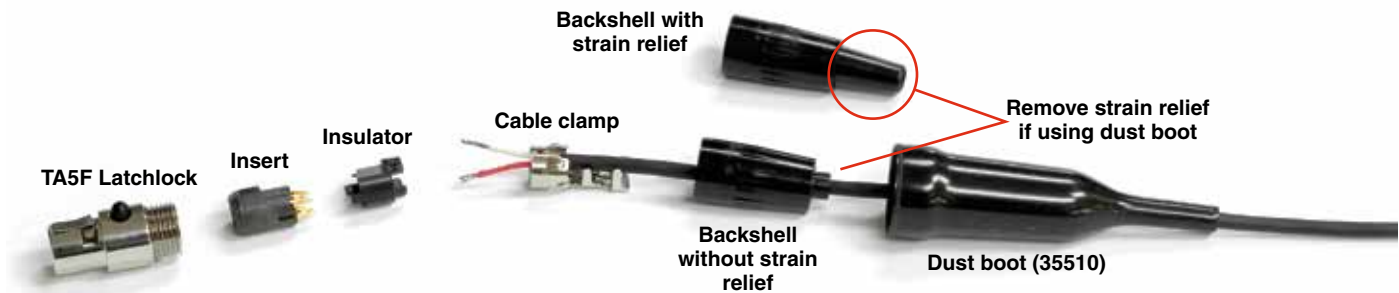

Note: If you use the dust boot, remove the rubber strain relief that is attached to the TA5F cap, or the boot will not fit over the assembly.

### Installing the Connector:

- 1) If necessary, remove the old connector from the microphone cable.
- 2) Slide the dust boot onto microphone cable with the large end facing the connector.
- 3) If necessary, slide the 1/8-inch black shrink tubing onto the microphone cable. This tubing is needed for some smaller diameter cables to ensure there is a snug fit in the dust boot.
- 4) Slide the backshell over the cable as shown above. Slide the insulator over the cable before soldering the wires to the pins on the insert.
- 5) Solder the wires and resistors to the pins on the insert according to the diagrams shown in **Wiring Hookups for Different Sources**. A length of .065 OD clear tubing is included if you need to insulate the resistor leads or shield wire.
- 6) If necessary, remove the rubber strain relief from the TA5F backshell by simply pulling it out.
- 7) Seat the insulator on the insert. Slide the cable clamp over the end of the insulator and crimp as shown on the next page.
- 8) Insert the assembled insert/insulator/clamp into the latchlock. Make sure the tab and slot align to allow the insert to fully seat in the latchlock. Thread the backshell onto the latchlock.

# Microphone Cable Termination for Non-Lectrosonics Microphones

## TA5F Connector Assembly

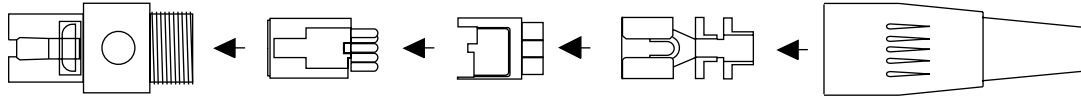

## Mic Cord Stripping Instructions

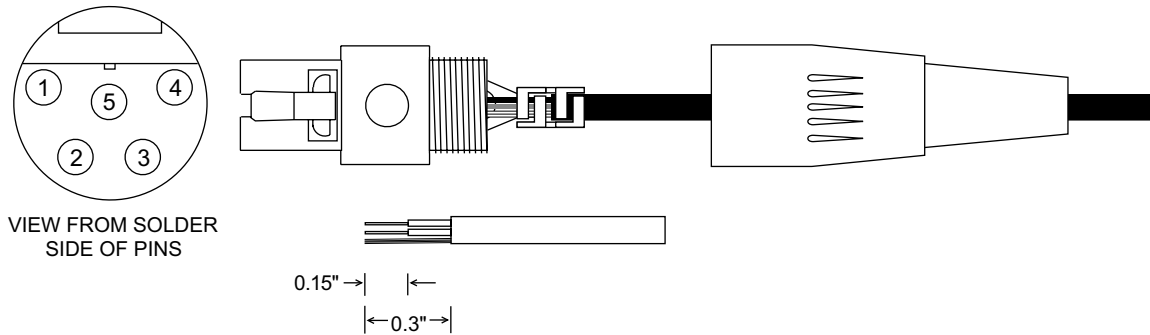

## Crimping to Shield and Insulation

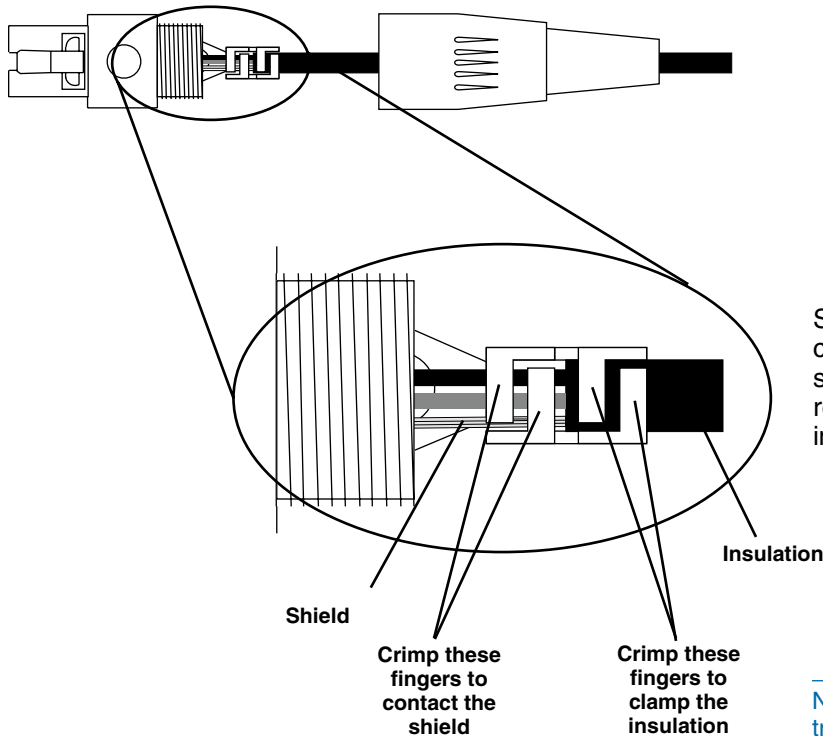

Strip and position the cable so that the clamp can be crimped to contact both the mic cable shield and the insulation. The shield contact reduces noise with some microphones and the insulation clamp increases ruggedness.

**NOTE:** This termination is intended for UHF transmitters and the PDR only. VHF transmitters with 5-pin jacks require a different termination. Lectrosonics lavalier microphones are terminated for compatibility with VHF and UHF transmitters, which is different from what is shown here.

# Wiring Hookups for Different Sources

In addition to the microphone and line level wiring hookups illustrated below, Lectrosonics makes a number of cables and adapters for other situations such as connecting musical instruments (guitars, bass guitars, etc.) to the transmitter. Visit [www.lectrosonics.com](http://www.lectrosonics.com) and click on Accessories, or download the master catalog.

A lot of information regarding microphone wiring is also available in the FAQ section of the web site at:

<http://www.lectrosonics.com>

Hover over Support and click on FAQs. Follow the instructions to search by model number or other search options.

## Compatible Wiring for Both Servo Bias Inputs and Earlier Transmitters:

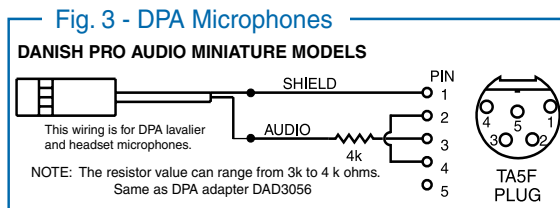
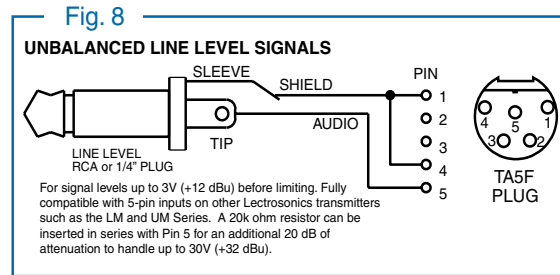
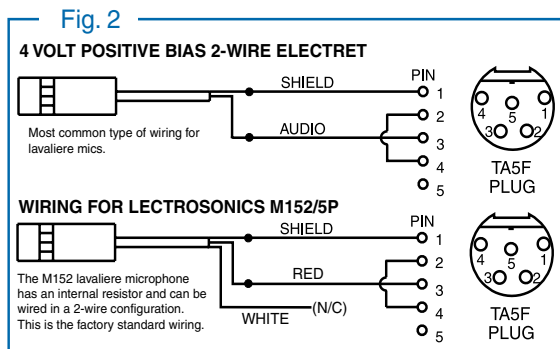
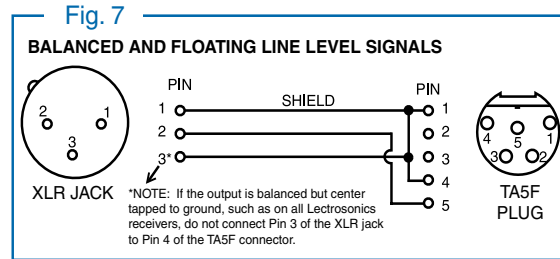
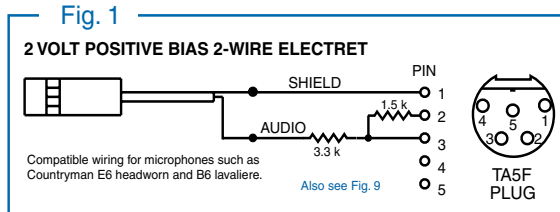

## Simple Wiring - Can ONLY be used with Servo Bias Inputs:

Servo Bias was introduced in 2005 and all transmitters with 5-pin inputs have been built with this feature since 2007.

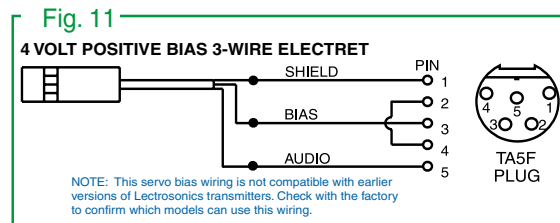
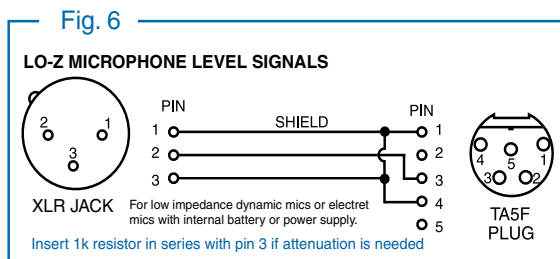
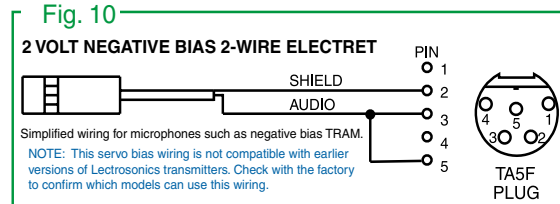
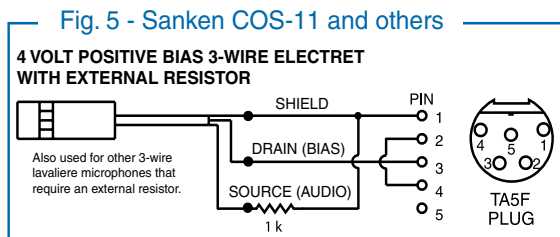
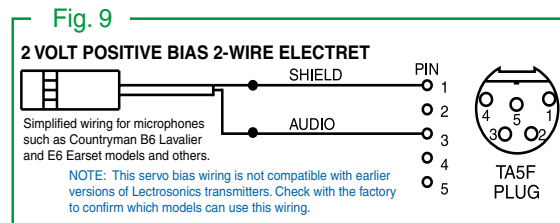
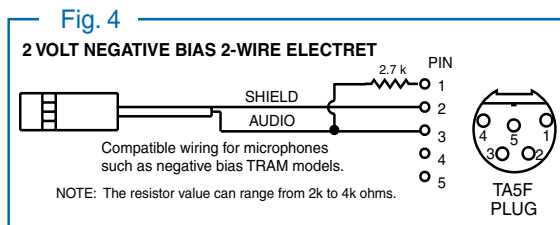

## Optional Accessories

**PDRWBC** PDR wire belt clip



**MC70** line level adapter cable. Male 3.5 mm TRS to female TA5F; 14 inches long. Feeds line level signal to pin 5 on the TA5M input jack.



**MC35** line level adapter cable. Female XLR to female TA5F; 37 inches long. Feed line level signal to pin 5 on the TA5M jack.



**MC41** mic level adapter cable. Female XLR to female TA5F; 37 inches long. Feeds mic level signal to pin 3 on the TA5M jack.



**P1354** dust and moisture plug for headphone/line output and timecode sync port.



# Specifications

## Recording

Storage media:	microSDHC memory card*
File format:	.wav files (BWF - Broadcast Wave File)
A/D converter:	24-bit
Sampling rate:	48 kHz
Recording modes/Bit rate:	<ul style="list-style-type: none"> <li>• HD mono mode: 24 bit - 144 kbytes/s 32 bit - 192 kbytes/s</li> <li>• Split gain mode: 24 bit - 288 kbytes/s 32 bit - 384 kbytes/s</li> </ul>

## Input

Type:	Analog mic/line level compatible; servo bias preamp for 2V and 4V lavalier microphones
Input level:	<ul style="list-style-type: none"> <li>• Dynamic mic: 0.5 mV to 50 mV</li> <li>• Electret mic: Nominal 2 mV to 300 mV</li> <li>• Line level: 17 mV to 1.7 V</li> </ul>
Input connector:	TA5M 5-pin male

## Headphone/Line Output

Connector:	3.5 mm mini jack; TRS
Maximum level:	-3 dBu (575 mV RMS)

## Audio Performance

Frequency response:	20 Hz to 20 kHz; +0.5/-1.5 dB
Dynamic range:	110 dB (A), before limiting
Distortion:	< 0.035%

## Timecode

Connector:	5-pin LEMO
Signal voltage:	0.5 Vp-p to 5Vp-p
Input impedance:	10 k Ohms
Format:	SMPTE 12M - 1999 compliant

## Battery Power/Life

Power consumption:	300 mW
Battery type:	AAA Lithium non-rechargeable (recommended)
AAA Lithium:	6.5 hours typical

## Operating temperature range

Celsius:	-20 to 50
Fahrenheit:	-5 to 122

## Dimensions and Weight

Dimensions:	Inches: 2.37H x 2.14W x 0.67D Millimeters: 60H x 54W x 17D
Weight:	71 grams (2.5 ozs.) w/ AAA Lithium battery

Specifications subject to change without notice.



\*microSDHC Logo is a trademark of SD-3C, LLC

# Available Recording Time

Using a microSDHC memory card, the available recording times are as follows. The actual time may vary slightly from the values listed in the tables.

## HD mono mode

Size	Hrs:Min
8GB	11:12
16GB	23:00
32GB	46:07

## Split gain mode

Size	Hrs:Min
8GB	5:36
16GB	11:30
32GB	23:03

This device complies with part 15 of the FCC Rules. Operation is subject to the following two conditions: (1) This device may not cause harmful interference, and (2) this device must accept any interference received, including interference that may cause undesired operation.

NOTE: This equipment has been tested and found to comply with the limits for a Class B digital device, pursuant to part 15 of the FCC Rules. These limits are designed to provide reasonable protection against harmful interference in a residential installation. This equipment generates, uses and can radiate radio frequency energy and, if not installed and used in accordance with the instructions, may cause harmful interference to radio communications. However, there is no guarantee that interference will not occur in a particular installation. If this equipment does cause harmful interference to radio or television reception, which can be determined by turning the equipment off and on, the user is encouraged to try to correct the interference by one or more of the following measures:

- Reorient or relocate the receiving antenna.
- Increase the separation between the equipment and receiver.
- Connect the equipment into an outlet on a circuit different from that to which the receiver is connected.
- Consult the dealer or an experienced radio/TV technician for help.



## Service and Repair

If your recorder malfunctions, you should attempt to correct or isolate the trouble before concluding that the equipment needs repair. Make sure you have followed the setup procedure and operating instructions and check the interconnecting cables.

We strongly recommend that you **do not** try to repair the equipment yourself and **do not** have the local repair shop attempt anything other than the simplest repair. If the repair is more complicated than a broken wire or loose connection, send the unit to the factory for repair and service. Don't attempt to adjust any controls inside the units. Once set at the factory, the various controls and trimmers do not drift with age or vibration and never require readjustment. **There are no adjustments inside that will make a malfunctioning unit start working.**

LECTROSONICS' Service Department is equipped and staffed to quickly repair your equipment. In warranty repairs are made at no charge in accordance with the terms of the warranty. Out-of-warranty repairs are charged at a modest flat rate plus parts and shipping. Since it takes almost as much time and effort to determine what is wrong as it does to make the repair, there is a charge for an exact quotation. We will be happy to quote approximate charges by phone for out-of-warranty repairs.

### Returning Units for Repair

For timely service, please follow the steps below:

- A.** DO NOT return equipment to the factory for repair without first contacting us by email or by phone. We need to know the nature of the problem, the model number and the serial number of the equipment. We also need a phone number where you can be reached 8 A.M. to 4 P.M. (U.S. Mountain Standard Time).
- B.** After receiving your request, we will issue you a return authorization number (R.A.). This number will help speed your repair through our receiving and repair departments. The return authorization number must be clearly shown on the **outside** of the shipping container.
- C.** Pack the equipment carefully and ship to us, shipping costs prepaid. If necessary, we can provide you with the proper packing materials. UPS is usually the best way to ship the units. Heavy units should be "double-boxed" for safe transport.
- D.** We also strongly recommend that you insure the equipment, since we cannot be responsible for loss of or damage to equipment that you ship. Of course, we insure the equipment when we ship it back to you.

#### Lectrosonics USA:

**Mailing address:**

Lectrosonics, Inc.  
PO Box 15900  
Rio Rancho, NM 87174  
USA

**Shipping address:**

Lectrosonics, Inc.  
561 Laser Rd., Suite 102  
Rio Rancho, NM 87124  
USA

**Telephone:**

(505) 892-4501  
(800) 821-1121 Toll-free  
(505) 892-6243 Fax

**Web:**

[www.lectrosonics.com](http://www.lectrosonics.com)

**E-mail:**

[sales@lectrosonics.com](mailto:sales@lectrosonics.com)

#### Lectrosonics Canada:

**Mailing Address:**

720 Spadina Avenue,  
Suite 600  
Toronto, Ontario M5S 2T9

**Telephone:**

(416) 596-2202  
(877) 753-2876 Toll-free  
(877-7LECTRO)  
(416) 596-6648 Fax

**E-mail:**

Sales: [sales@lectrosonics.com](mailto:sales@lectrosonics.com)  
Service: [joeb@lectrosonics.com](mailto:joeb@lectrosonics.com)





## LIMITED ONE YEAR WARRANTY

The equipment is warranted for one year from date of purchase against defects in materials or workmanship provided it was purchased from an authorized dealer. This warranty does not cover equipment which has been abused or damaged by careless handling or shipping. This warranty does not apply to used or demonstrator equipment.

Should any defect develop, Lectrosonics, Inc. will, at our option, repair or replace any defective parts without charge for either parts or labor. If Lectrosonics, Inc. cannot correct the defect in your equipment, it will be replaced at no charge with a similar new item. Lectrosonics, Inc. will pay for the cost of returning your equipment to you.

This warranty applies only to items returned to Lectrosonics, Inc. or an authorized dealer, shipping costs prepaid, within one year from the date of purchase.

This Limited Warranty is governed by the laws of the State of New Mexico. It states the entire liability of Lectrosonics Inc. and the entire remedy of the purchaser for any breach of warranty as outlined above. NEITHER LECTROSONICS, INC. NOR ANYONE INVOLVED IN THE PRODUCTION OR DELIVERY OF THE EQUIPMENT SHALL BE LIABLE FOR ANY INDIRECT, SPECIAL, PUNITIVE, CONSEQUENTIAL, OR INCIDENTAL DAMAGES ARISING OUT OF THE USE OR INABILITY TO USE THIS EQUIPMENT EVEN IF LECTROSONICS, INC. HAS BEEN ADVISED OF THE POSSIBILITY OF SUCH DAMAGES. IN NO EVENT SHALL THE LIABILITY OF LECTROSONICS, INC. EXCEED THE PURCHASE PRICE OF ANY DEFECTIVE EQUIPMENT.

This warranty gives you specific legal rights. You may have additional legal rights which vary from state to state.



581 Laser Road NE • Rio Rancho, NM 87124 USA • [www.lectrosonics.com](http://www.lectrosonics.com)  
(505) 892-4501 • (800) 821-1121 • fax (505) 892-6243 • [sales@lectrosonics.com](mailto:sales@lectrosonics.com)

06 June 2018